

**SORTER STAPLER**  
**(Machine Code: A366)**

# 1. SPECIFICATIONS

- Configuration: Console
- Number of Bins: 20 + Proof Tray
- Paper for Proof Tray: Size: Maximum: A3, 11" x 17"  
 Minimum: A6 lengthwise, 5 1/2" x 8 1/2"  
 Weight: 52~157 g/m<sup>2</sup>, 14~41lb
- Paper for Bins: Sort/Stack mode  
 Size: Maximum: A3, 11" x 17"  
 Minimum: A5 lengthwise, 5 1/2" x 8 1/2" lengthwise  
 Weight: 52~93 g/m<sup>2</sup>, 14~24 lb
- Staple mode  
 Size: Maximum: A3, 11" x 17"  
 Minimum: B5, 8 1/2" x 11"  
 Weight: 64~80g/m<sup>2</sup>, 17~20 lb
- Paper Capacity: Proof tray: 150 sheets (80 g/m<sup>2</sup>, 20 lb)  
 Bins:

	1 sided copies	2 sided copies
Sort mode	50 Sheets	50 Sheets
Stack mode	40 Sheets	35 Sheets

(80 g/m<sup>2</sup>, 20 lb)

Staple Capacity: From 2 to 30 sheets (80 g/m<sup>2</sup>, 20 lb)

Staple Position:

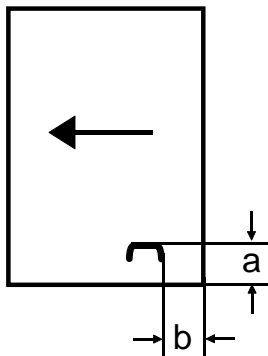

a = 5 ± 2 mm (0.2" ±0.08")  
 b = 5 ± 2 mm (0.2" ±0.08")



Staple Time:	Within 2 seconds/staple
Staple Replenishment:	Cartridge exchange (5,000 pieces/cartridge)
Power Source:	AC 100 V (from copier)
Power Consumption:	Average: less than 80 W Maximum: in sort/stack mode: less than 90 W in staple mode: less than 170 W
Dimensions: (W x D x H)	610 x 675 x 1035 mm 24.1" x 26.6" x 40.8"
Weight:	Approximately 80 kg (177 lb)

## 2. COMPONENT LAYOUT

### 2.1 MECHANICAL COMPONENT LAYOUT

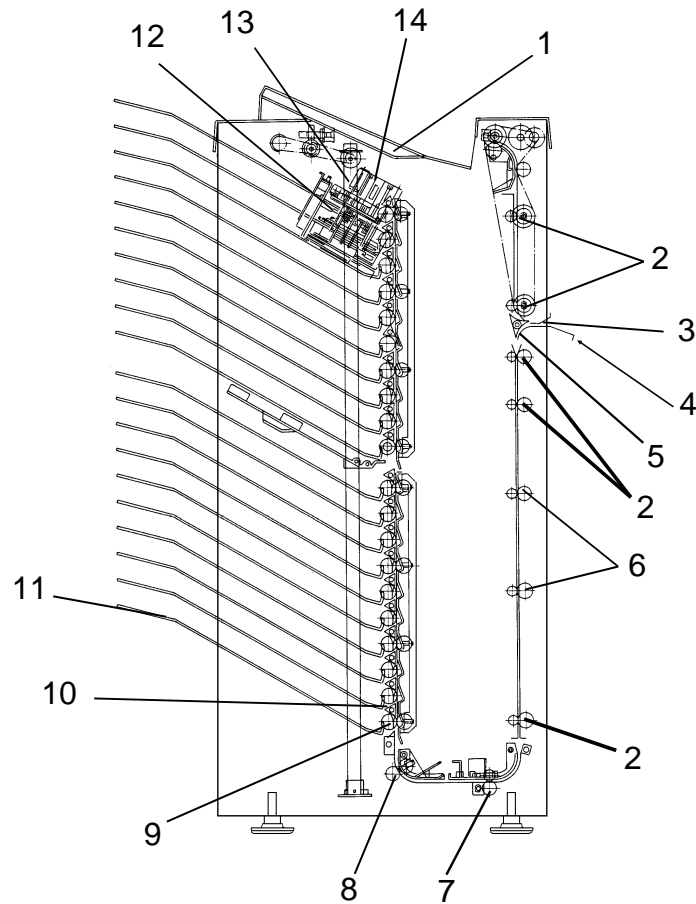

- |                                    |                                    |
|------------------------------------|------------------------------------|
| 1. Proof Tray                      | 8. 2nd Horizontal Transport Roller |
| 2. Vertical Transport Rollers      | 9. Distribution Rollers            |
| 3. Upper Entrance Guide            | 10. Bin Gates                      |
| 4. Lower Entrance Guide            | 11. Bins                           |
| 5. Turn Gate                       | 12. Grip Assembly                  |
| 6. Diagonal Transport Rollers      | 13. Jogger Plate                   |
| 7. 1st Horizontal Transport Roller | 14. Stapler                        |

**2.2 DRIVE LAYOUT**

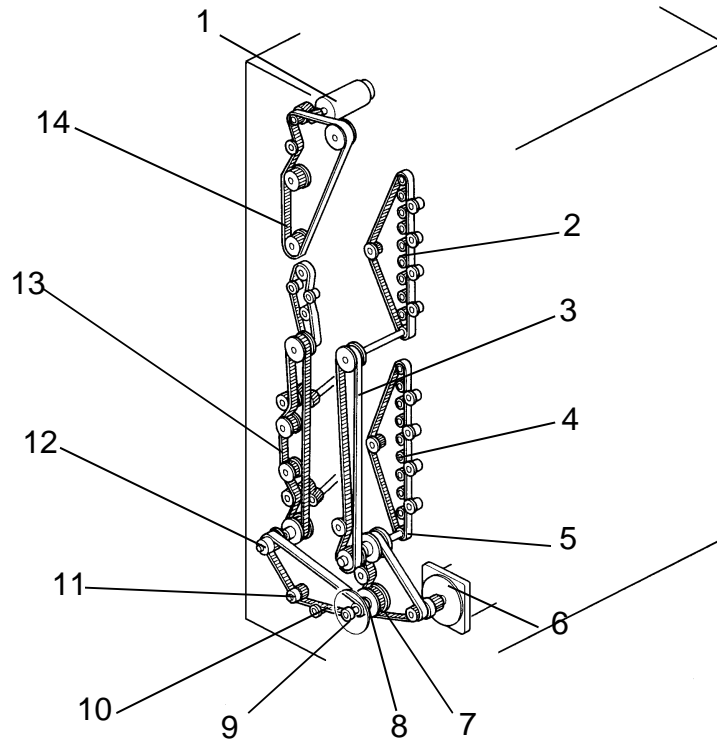

The drive train is as follows:

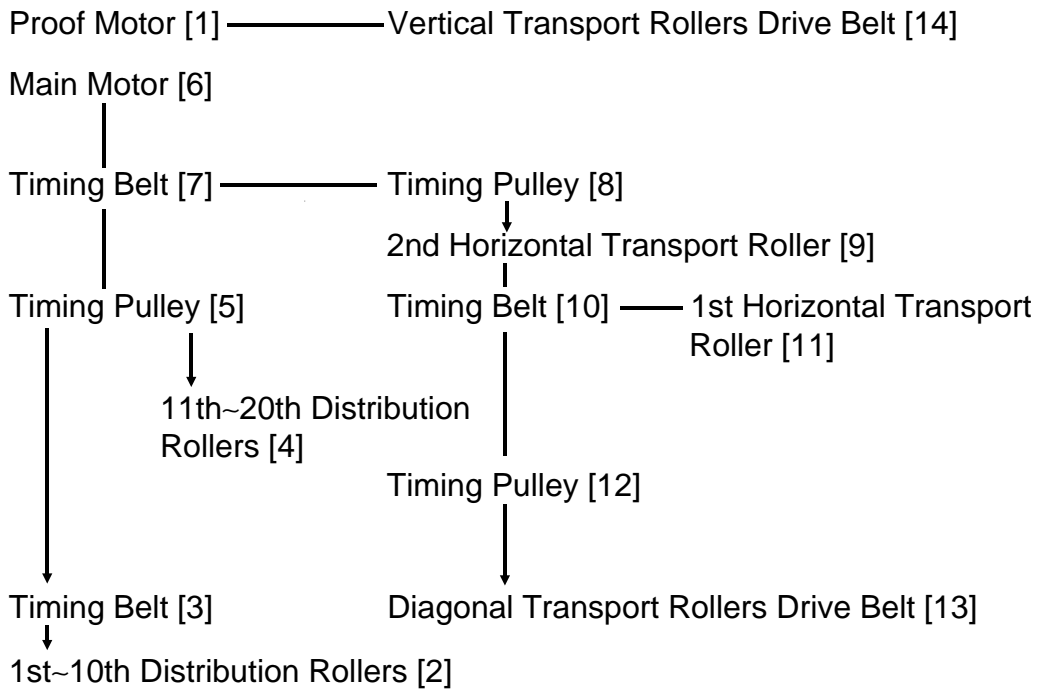

## 2.3 ELECTRICAL COMPONENT DESCRIPTION

Please refer to the Electrical Component Layout on the Reverse side of the Point to Point (Water Proof Paper) for symbol and index number.

SYMBOL	NAME	FUNCTION	INDEX NO.
<b>Motors</b>			
M1	Proof	Drives the vertical transport rollers.	1
M2	Staple Unit Drive	Drives the staple unit up and down to the appropriate bin.	5
M3	Stapler	Feeds the staples and drives the stapler hammer.	9
M4	Grip	Drives the grippers forward and backward into the bin to grip the copies and bring them to the stapling position.	11
M5	Bin Side Plate Drive	Drives the bin side plate.	16
M6	Jogger	Drives the jogger plate to jog the copies against the bin side plate.	20
M7	Main	Drives the distribution, horizontal transport, and diagonal transport rollers.	21
<b>Sensors</b>			
S1	Exit	Detects paper jams at the sorter exit (Proof Tray).	2
S2	Staple Unit H.P.	Detects if the staple unit is in the home position.	6
S3	Grip H.P.	Detects if the grippers are in the home position.	10
S4	Staple Unit Position	Detects the position of the staple unit.	12
S5	Bin Transport	Detects paper jams between the entrance guide and the horizontal transport rollers in the sort/stack or staple mode.	15
S6	Bin Side Plate Release	Detects if the bin side plate is in the released position.	18

Sorter Stapler

<b>SYMBOL</b>	<b>NAME</b>	<b>FUNCTION</b>	<b>INDEX NO.</b>
S7	Bin Side Plate H.P.	Detects if the bin side plate is in the home position.	19
S8	Jogger H.P.	Detects if the jogger plate is in the home position.	22
S9	Timing	Provides pulses to the sorter stapler main control board.	24
S10	Bin/Jam (LED)	Detects if there is paper jams at the distribution section and detects if there is paper in the bins (light emitting element).	30
<b>Sensors</b>			
S11	Bin/Jam (Photo Tr.)	Detects paper jams at the distribution section and detects if there is paper in the bins (light receiving element)	17
S12	Paper	Detects whether copies are under the hammer.	14
S13	Staple H.P.	Detects if the staple hammer is in the home position.	8
S14	Staple End	Detects the staple end.	7
<b>Switches</b>			
SW1	Door Safety	Controls the 100 V ac line.	4
SW2	Door Safety	Controls the 24 V dc line.	3
<b>Solenoids</b>			
SOL 1	Grip	Opens and closes the grippers to grip copies on the bins.	13
SOL 2 ~20	Bin	Opens and closes the bin gate to direct the copies into the appropriate bin.	28
SOL 21	Turn Gate	Opens and closes the turn gate to direct the copies into either the proof tray or the bins.	29

<b>SYMBOL</b>	<b>NAME</b>	<b>FUNCTION</b>	<b>INDEX NO.</b>
<b>Circuit Board</b>			
PCB 1	Main Control	Controls all sorter stapler functions.	26
PCB 2	Bin Solenoid	Interfaces between the bin gate solenoids (sol 2~10) and the main control board.	27
PCB 3	Bin Solenoid	Interfaces between the bin gate solenoids (sol 11~20) and the main control board.	25
<b>Capacitor</b>			
C	Main Motor	Motor start capacitor.	23



### 3. BASIC OPERATION

#### 3.1 NORMAL MODE AND SORT/STACK MODE

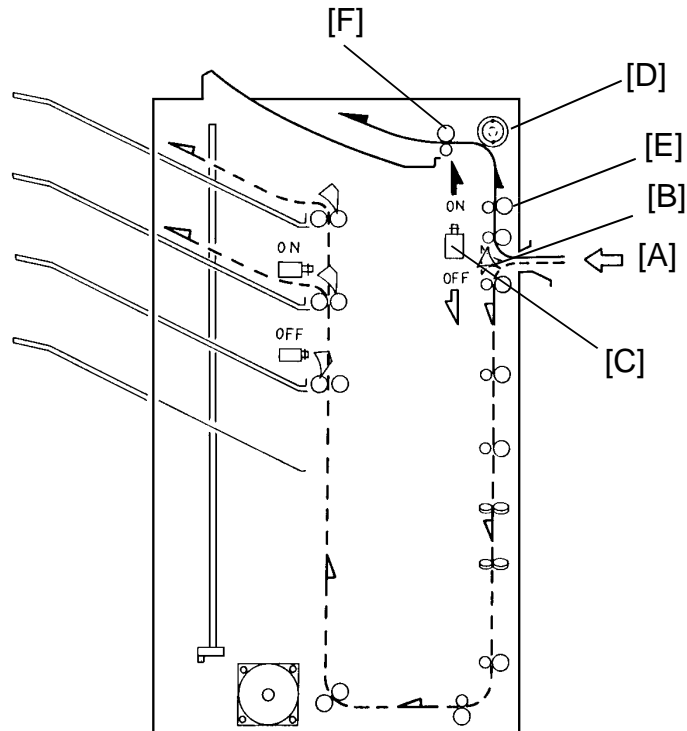

Copies exiting the copier pass through the entrance guide plates [A] to the turn gate section. The turn gate [B] will send copies either to the proof tray or to the bins, depending on the mode.

- **Normal mode** - (from the turn gate section to the proof tray)

The turn gate solenoid [C] is energized and the turn gate turns clockwise when the start key is pressed. The proof motor [D] rotates the vertical transport rollers [E] and exit roller [F]. The turn gate directs copies through the vertical transport section to the proof tray.

In this mode, if a misfeed is detected in the sorter stapler, the proof motor stops and the turn gate solenoid turns off. The main motor starts rotating. Copies going through the copier are sent to the 1st bin through the diagonal transport, horizontal transport, and distribution section.

- **Sort/Stack mode** - (from the turn gate section to the bins)

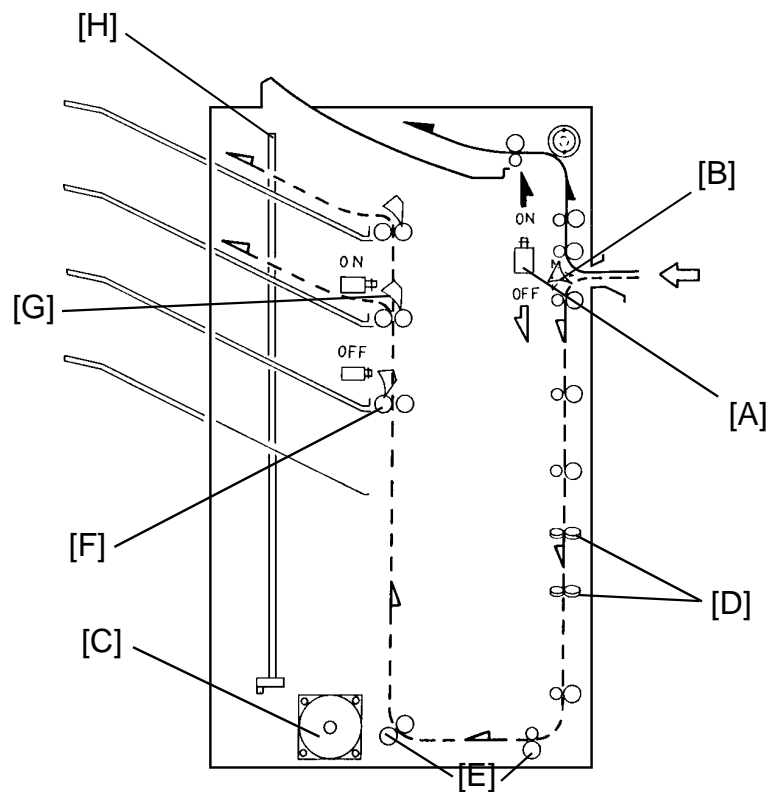

The turn gate solenoid [A] stays off and the turn gate [B] also stays up when the start key is pressed. The main motor [C] rotates the diagonal transport rollers [D], horizontal transport rollers [E], and distribution rollers [F].

The turn gate directs copies to the diagonal transport section. The diagonal transport section feeds copies diagonally. This is because copies are brought to the front side in advance for easier jogging.

Copies are directed to the distribution section through the diagonal and horizontal transport section. The appropriate bin gate [G] opens and copies are delivered to each bin.

The jogger plate [H] then jogs to square the copies each time.

In this mode, if a misfeed is detected in the sorter stapler, the main motor stops. The proof motor starts rotating and the turn gate solenoid energizes. Copies going through the copier are directed to the proof tray.

### 3.2 STAPLE MODE

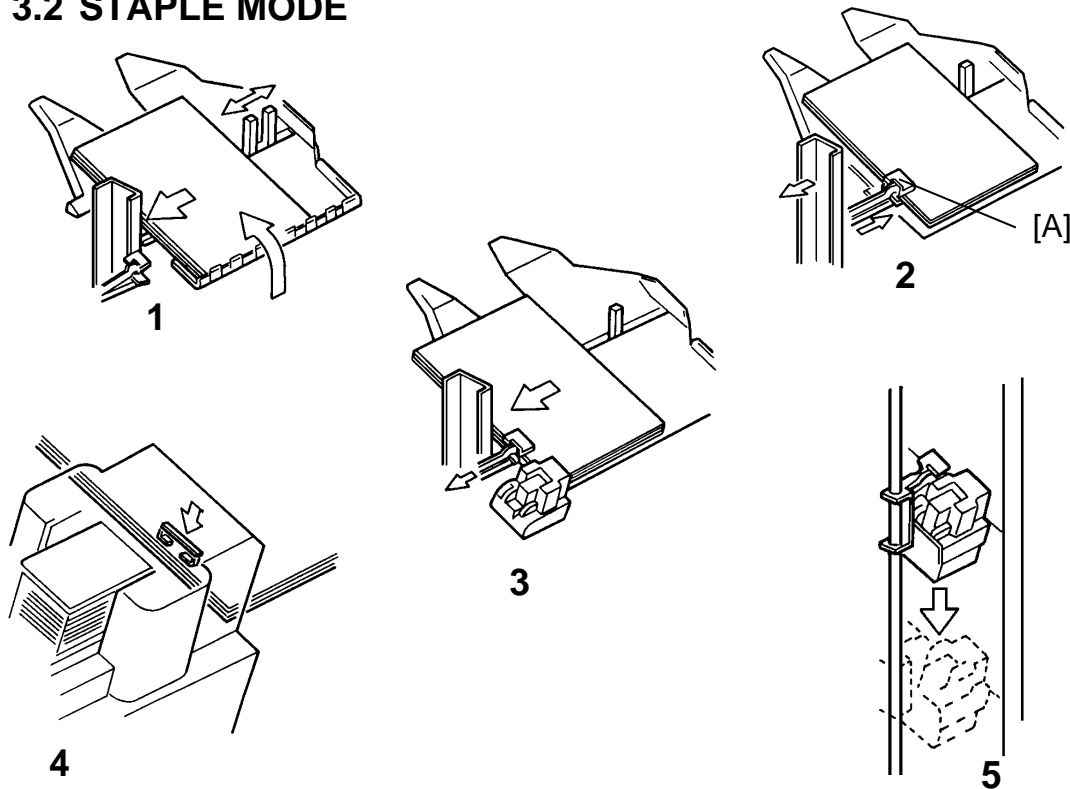

When the final set of copies is jogged in the sort mode (figure 1), the staple unit staples the stacked copies as follows:

The grippers (A) move forward, and grip the copies (figure 2). The grippers bring the copies up underneath the stapler (figure 3). The stapler staples the copies (figure 4). The copies are pushed back into the bin. The grippers open and return to the home position. The staple unit moves to the next bin (figure 5).

When the final set of copies is stapled, the staple unit is raised to the home position.

There are two staple modes.

1) Automatic stapling:

In ADF mode, when the staple mode is selected before pressing the start key, copies will be delivered to each bin and stapled automatically.

2) Manual stapling:

In sort mode, after copies are sorted in bins, the copies will be stapled when the staple key is pressed. In stack mode, manual stapling is impossible.

## 4. TURN GATE SECTION

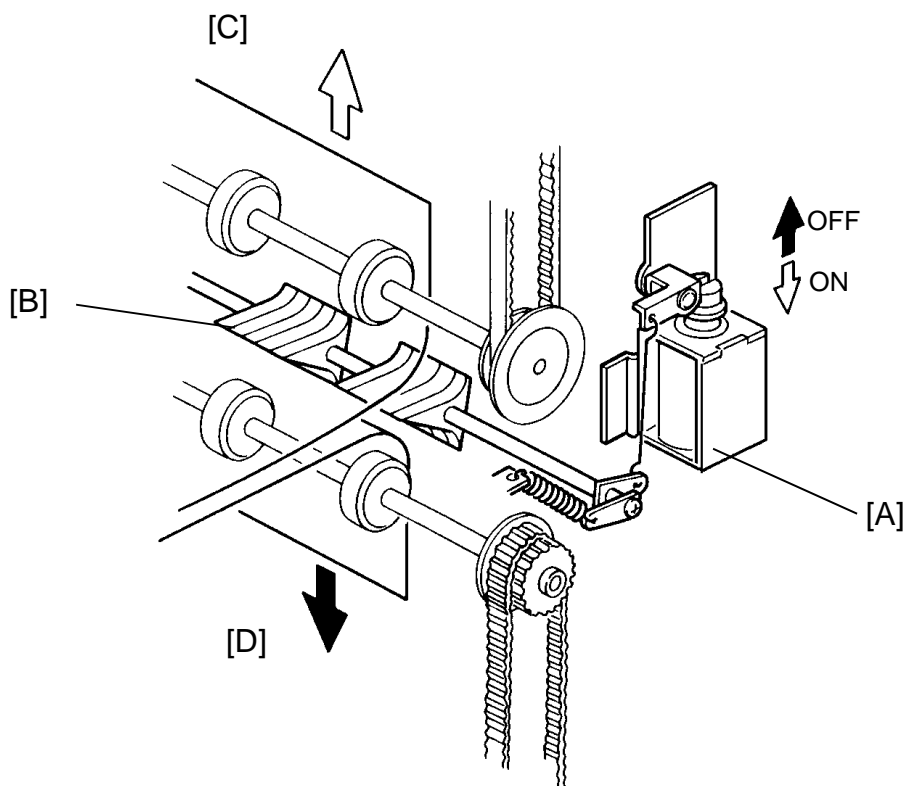

The turn gate sends copies to the proof tray or the bins depending on the mode. In the normal mode, the turn gate solenoid [A] turns on. The turn gate [B], directs copies upward [C] through the vertical transport section to the proof tray.

In the sort, stack, or staple mode, the turn gate solenoid stays off. The turn gate directs copies downward [D] to the diagonal transport section.

---

## 5. DIAGONAL TRANSPORT SECTION

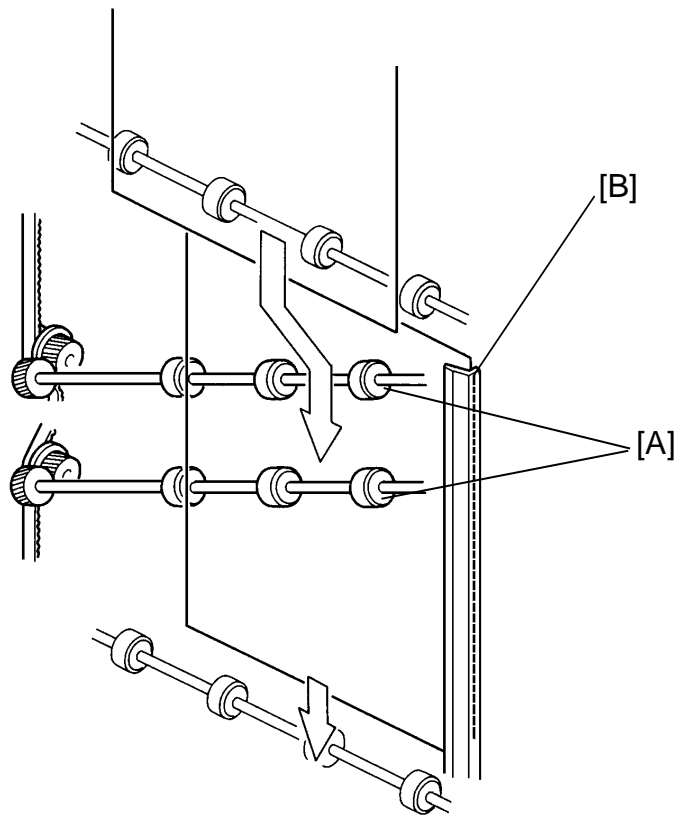

In the sort, stack, or staple mode, the diagonal transport rollers [A] bring the copies to the front side during transportation. Copies go to the horizontal transport section along the diagonal transport stopper [B].

## 6. DISTRIBUTION SECTION

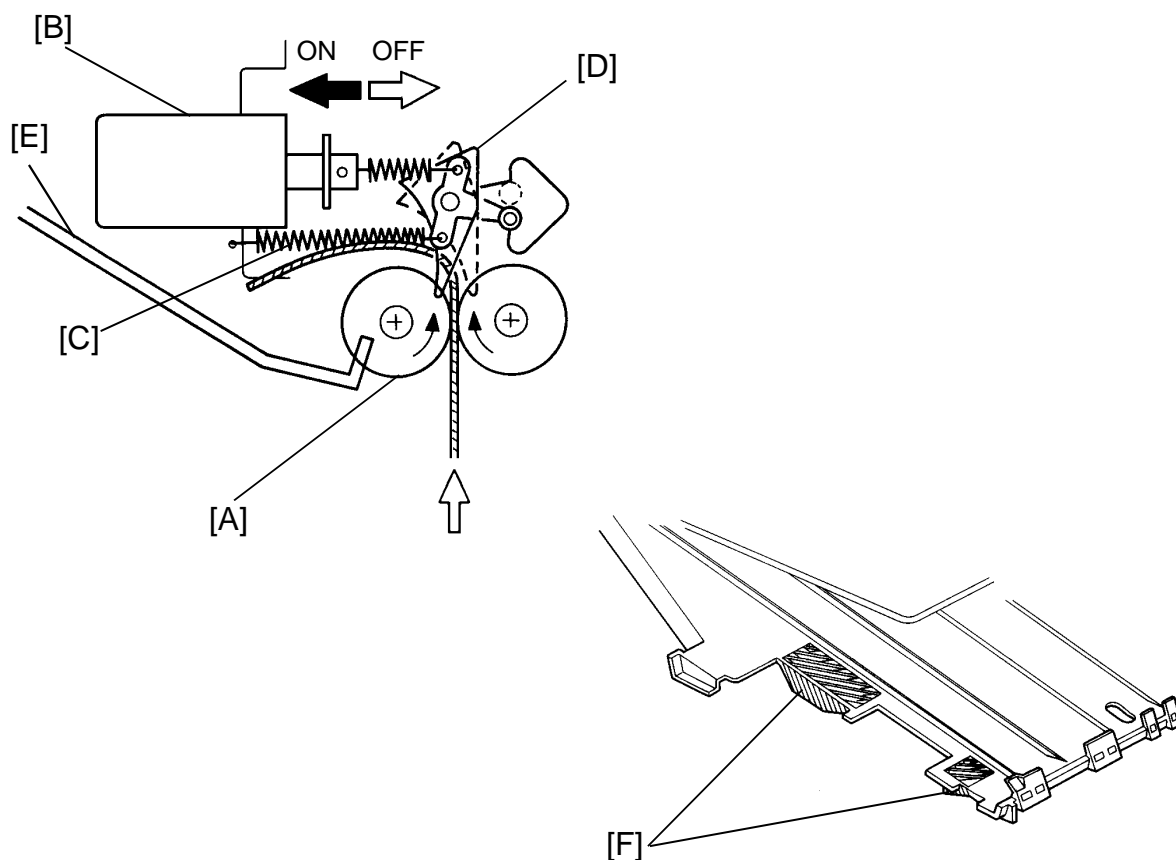

The distribution section has the distribution rollers [A], 20 bin gates, and 19 bin gate solenoids (the 1st bin gate is always open).

When a bin gate solenoid [B] is off, the return spring [C] holds the bin gate [D] out of the paper path, allowing the copies to pass to the upper bin.

The appropriate bin gate solenoid turns on and opens the bin gate. The other solenoids are off. The copies go to the bin [E] through the gate.

To prevent copies from curling and so causing misstapling or wrong staple positioning, the bin has paper flatteners [F] on the front side of the bin.

## 7. JOGGER SECTION

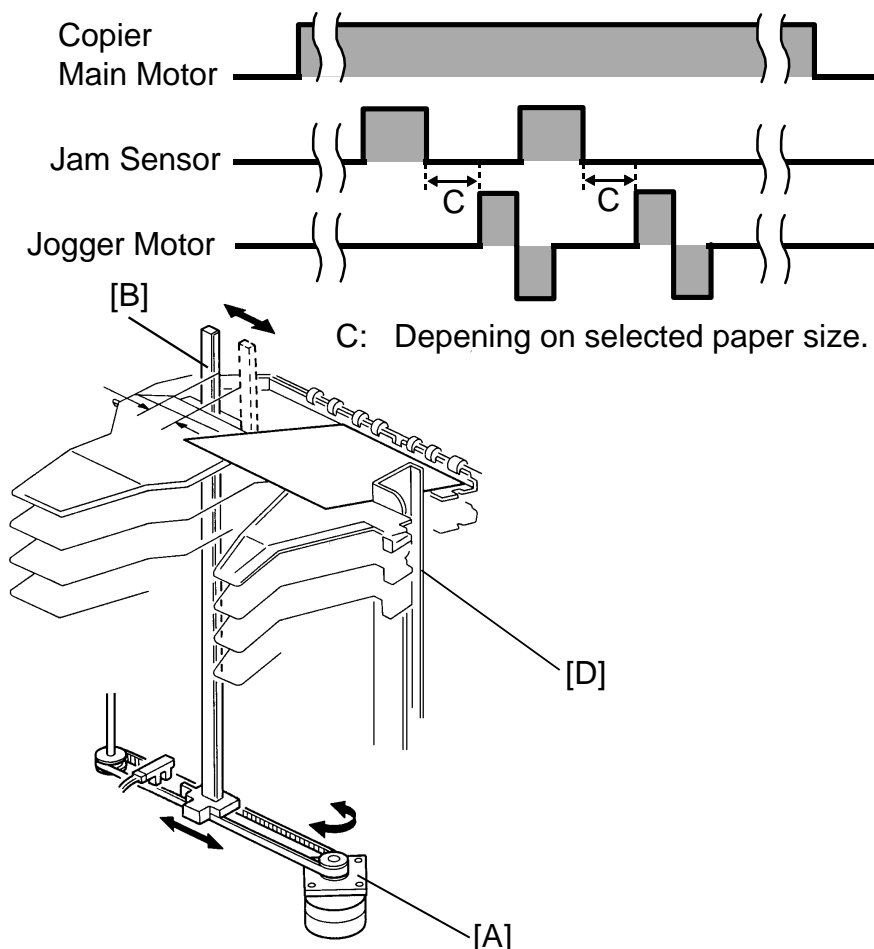

When the start key is pressed in the sort, stack, or staple mode, the copier sends the paper size information to the sorter stapler unit. In accordance with this data, the jogger motor [A] drives the jogger plate [B] from the jogger home position to where the width is 10 mm wider than the selected paper.

After the trailing edge of a copy passes the jam sensor (the bin/jam sensor), and after the appropriate timing [C] for the selected paper, the jogger motor rotates and reverses. This makes the jogger plate push all the copies against the bin side plate [D] to square the stack. Also, this makes the jogger plate return to where the width is 10 mm wider than the selected paper for the next copy.

When the bin sensor in the bin/jam sensor detects that all copies are removed from the bins after jogging is finished, the jogger plate returns to its home position.

**- Jogger off conditions -**

1. Under the following conditions, the jogger plate does not jog after copies are delivered to the bins.
  - If paper is loaded in a bin by hand while the sort/stack, or staple mode is selected.
  - If the selected paper size does not match stapling specifications.
  - If copies of different width are delivered to the bins.
2. If paper is in a bin before the main switch is turned on, the sort/stack mode is disabled when the sorter key is pressed.



## 8. BIN SIDE PLATE DRIVE SECTION

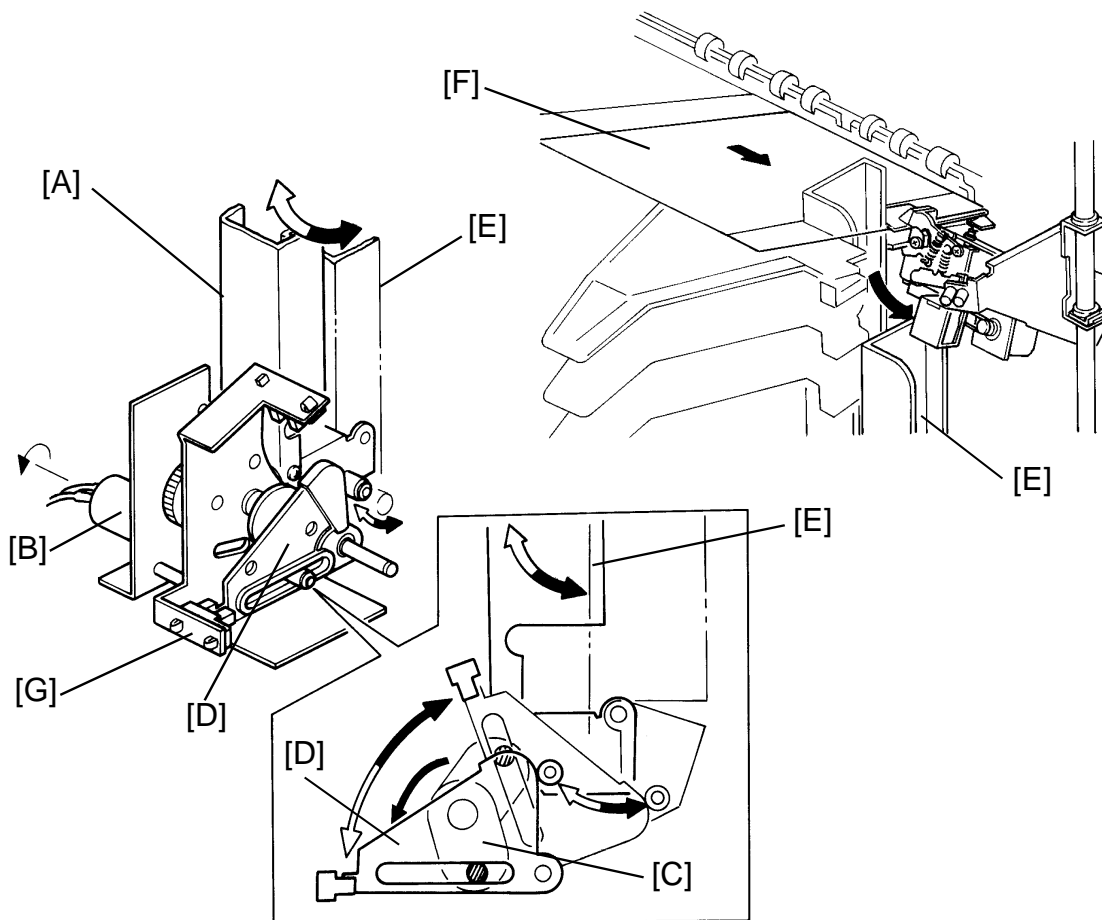

The bin side plate [A] is always in the home position except during the staple operation. The bin side plate takes part in the jogger function (see jogger section).

In the staple mode when all the copies have been jogged by the jogger plate, the bin side plate drive motor [B] rotates the cam drive plate [C]. The pin on the cam drive plate raises and lowers the actuator cam [D], and the actuator cam makes the bin side plate [E] move to the front side. Thus, the bin side plate does not interfere with the copies [F] being brought to the staple position by the grip assembly.

When the staple operation for the final set of copies is completed, the bin side plate drive motor rotates the cam drive plate until the bin side plate home position sensor [G] is actuated. This makes the bin side plate return to the home position.

## 9. STAPLE UNIT

### 9.1 STAPLE UNIT DRIVE MECHANISM

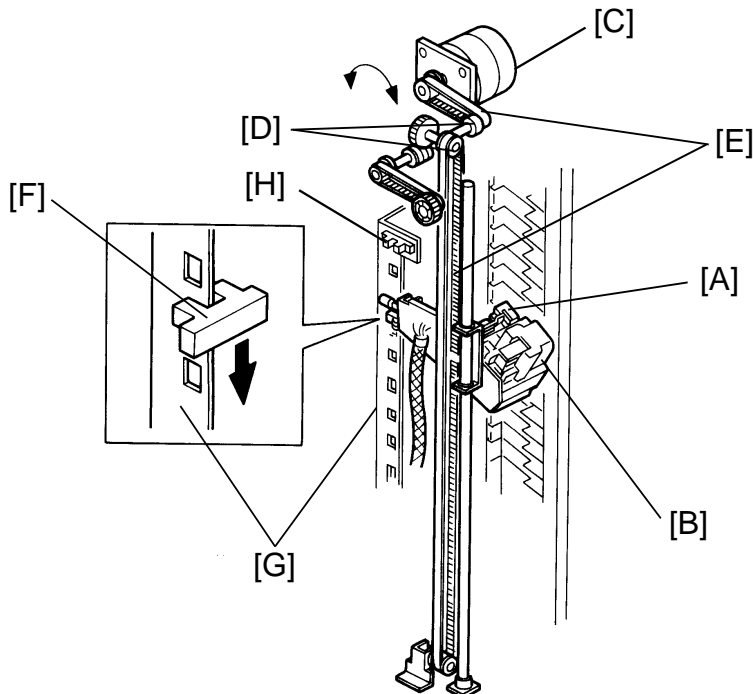

The staple unit consists of the grip assembly [A] and the stapler [B]. The staple unit is lowered from the home position (the first bin) to the 20th bin in order to staple the copies in each bin. The grip assembly grips the copies stacked in the bin and positions them underneath the stapler. The stapler staples the copies.

When the first set of copies is stapled, the staple unit drive motor [C] drives the staple unit downward via timing pulleys [D], and timing belts [E]. While the staple unit is being lowered, the staple unit position sensor [F] tracks the position actuator plate [G], generating an on/off signal that is sent to the sorter stapler main control board. This way, the position of the staple unit is detected and the staple unit drive motor stops the staple unit when it reaches the next bin. When the last set of copies in the bin is stapled, the staple unit drive motor reverses until the staple unit home position sensor [H] is actuated. At this time, the staple unit is in the home position.

Because lifting the unit requires more torque than lowering it, the lifting speed is about one third of the lowering speed.

## 9.2 GRIP ASSEMBLY

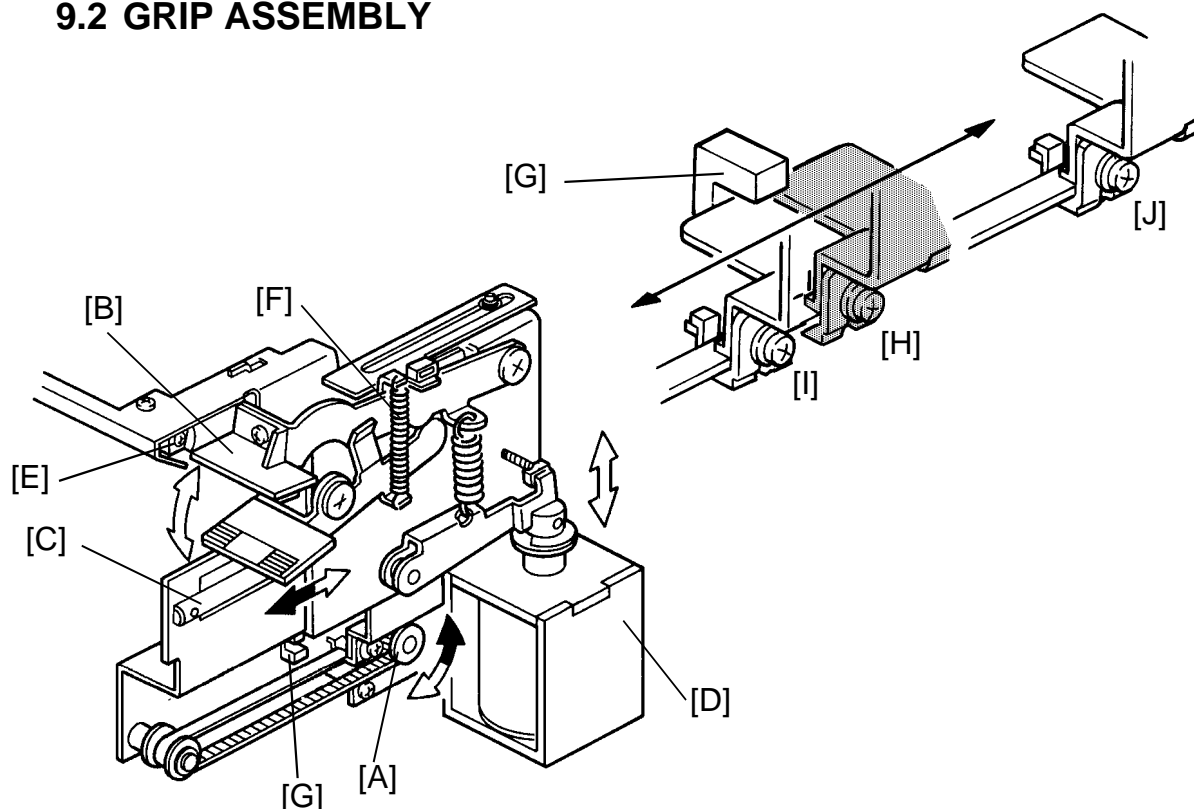

When the bin side plate starts moving to the front side, the grip motor [A] drives the grippers [B] into the bin. The grippers track the gripper guide [C]. The grip motor stops the grippers at the grip position. The grip solenoid [D] is energized and it closes the grippers to grip copies in the bin. When the bin side plate reaches the front side, the grip motor reverses and brings the grippers with the copies to the staple position. The paper sensor [E] checks if copies are brought to the staple position correctly. Then, the copies are stapled, and the grip motor drives the grippers with the stapled copies back into the bin.

When the grip solenoid turns off, the return spring [F] opens the grippers. The copies remain in the bin. Then, the grippers return to the home position for the next cycle.

The grip home position sensor [G] is actuated while the grippers move from the home position [H] to the grip position [I]. This sensor is deactivated while the grippers move from the home position to the staple position [J]. The sorter stapler main control board sends the appropriate pulses to the grip motor (stepper motor) to determine the grip position and staple position.

When the main switch is turned on, the grip motor turns forward and backward to check whether the grippers are in the home position. If not, the grip motor returns the grippers to their home position.

### 9.3 STAPLER

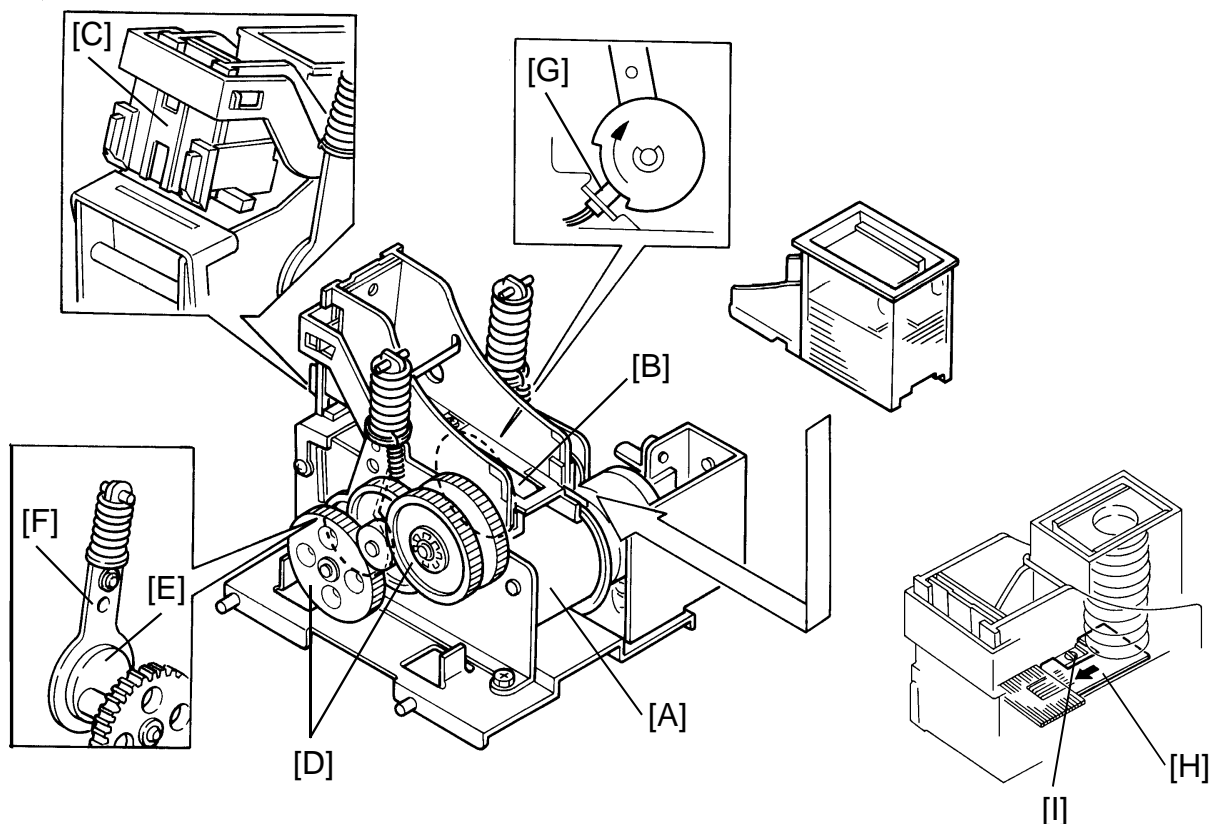

The stapler motor [A] drives the staple sheet drive belt [B].

The staple sheets are fed under the hammer [C].

The stapler motor drives the staple hammer via gears [D], two eccentric cams [E], and two links [F].

When the aligned copies are brought to the staple position by the grippers, the stapler motor starts rotating. When the cams complete one rotation, the staple home position sensor [G] is deactuated. The stapler motor then stops.

When the paper sensor in the grip assembly does not detect that the copies are under the hammer, the stapler motor does not rotate.

A paper sheet [H] with a notch cut-in is positioned at the bottom of the staple cartridge. This paper sheet is fed out after the last staple sheet. When the leading edge of the notch in the sheet is detected by the staple end sensor [I], the sorter stapler unit recognizes the staple near end condition. After the job is completed, the Add Staple indicator lights on the copier operation panel and the Start key turns to red whenever the staple mode is selected.

**- Staple prohibit conditions -**

1. Under the following conditions, the staple mode is prohibited when the staple key on the operation panel is pressed.
  - If paper is in a bin before the main switch is turned on.
  - If the selected paper size does not match stapling specifications.
  
2. Under the following conditions, the staple mode is canceled.
  - If paper is loaded in a bin by hand while the staple mode is selected.
  - If only one sheet is delivered to the bin.
  - If the number of sheets stapled exceeds the staple capacity.
  
3. Under the following conditions, the manual stapling mode in sort mode is prohibited.
  - If paper is loaded in a bin by hand while the sort mode is selected.
  - If the paper size in the bin does not match stapling specifications.
  - If only one sheet is delivered to the bin.
  - If copies of different width are delivered to the bin.
  - If copies already stapled are left in the bin.

## 10. JAM DETECTION AND STAPLE ERROR

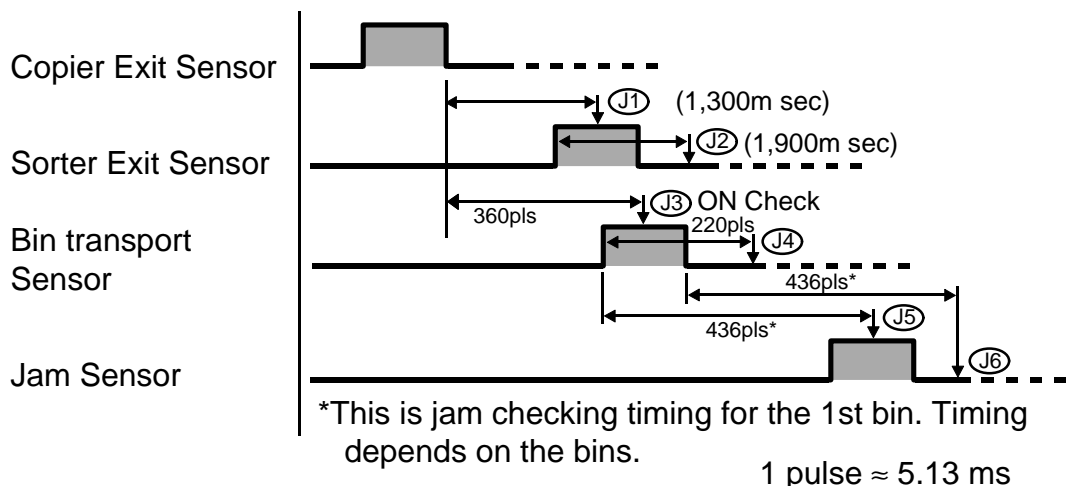

### 10.1 SORTER JAMS

The sorter stapler main control board detects jams when the following conditions are detected. In these cases, a jam signal is sent to the copier, the copier stops the paper feed and indicates a sorter misfeed.

#### - Normal mode -

J1: The sorter exit sensor has not turned on for 1,300 ms after the copier exit sensor turns off (paper check).

J2: The sorter exit sensor stays on for 1,900 ms or more (no paper check).

#### - In sort/stack or staple mode -

J3: The bin transport sensor has not turned on for 360 pulses after the copier exit sensor turns on (paper check).

J4: The bin transport sensor stays on for 220 pulses (no paper check).

J5: The jam sensor has not turned on for the appropriate number of pulses after the bin transport sensor turns on (paper check). This number depends on the bin. (See the diagram in the next page.)

J6: The jam sensor has not turned off after the appropriate number of pulses after the bin transport sensor turns off (no paper check). This number depends on the bin. (See the diagram in the next page.)

**- Jam checking timing diagram -**

Bin no.	Pulses	Bin no.	Pulses
1	436	11	294
2	422	12	280
3	408	13	266
4	394	14	252
5	382	15	240
6	368	16	226
7	354	17	214
8	342	18	200
9	328	19	186
10	314	20	174

**10.2 STAPLE ERROR**

The sorter stapler main control board detects a staple error when the following conditions are detected.

- Error 1      The paper sensor in the grip assembly turns on (paper is still in the grip assembly) while the staple unit is being lowered. In this case, a staple error signal is sent to the copier. The copier cancels the staple mode and indicates a staple error.

After paper left in the grippers is removed, the staple unit returns to the home position. When the staple key is pressed, the stapler begins to staple the rest of the copies starting from the bin following the bin where the jam happened.

- Error 2      The paper sensor in the grip assembly does not turn on (paper is not in the grip assembly) when the grippers are in the staple position. In this case, the staple unit skips stapling this bin and moves to the next bin for stapling.

# 11.TIMING CHART

**Timing Chart 1** (Normal mode: B5 sideways 5 copies)

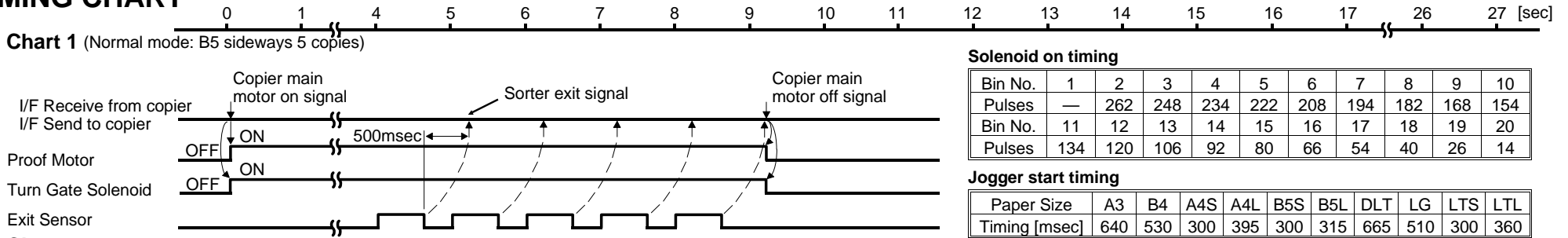

**Solenoid on timing**

Bin No.	1	2	3	4	5	6	7	8	9	10
Pulses	—	262	248	234	222	208	194	182	168	154
Bin No.	11	12	13	14	15	16	17	18	19	20
Pulses	134	120	106	92	80	66	54	40	26	14

**Jogger start timing**

Paper Size	A3	B4	A4S	A4L	B5S	B5L	DLT	LG	LTS	LTL
Timing [msec]	640	530	300	395	300	315	665	510	300	360

S: Sideways L: Lengthways

**Timing Chart 2** (Sort & Staple mode: B5 sideways 2 originals x 5 copies)

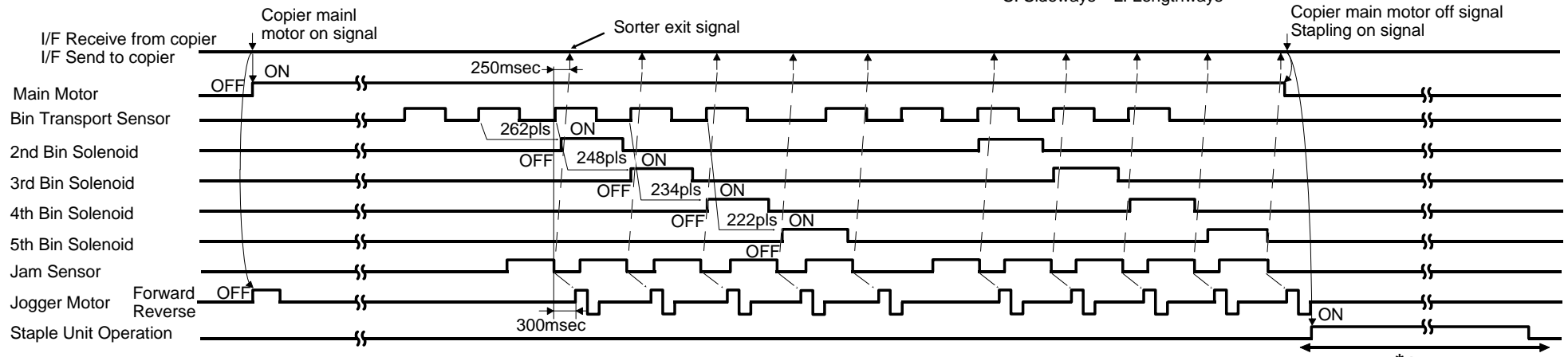

**\*A** (Staple Unit Operation)

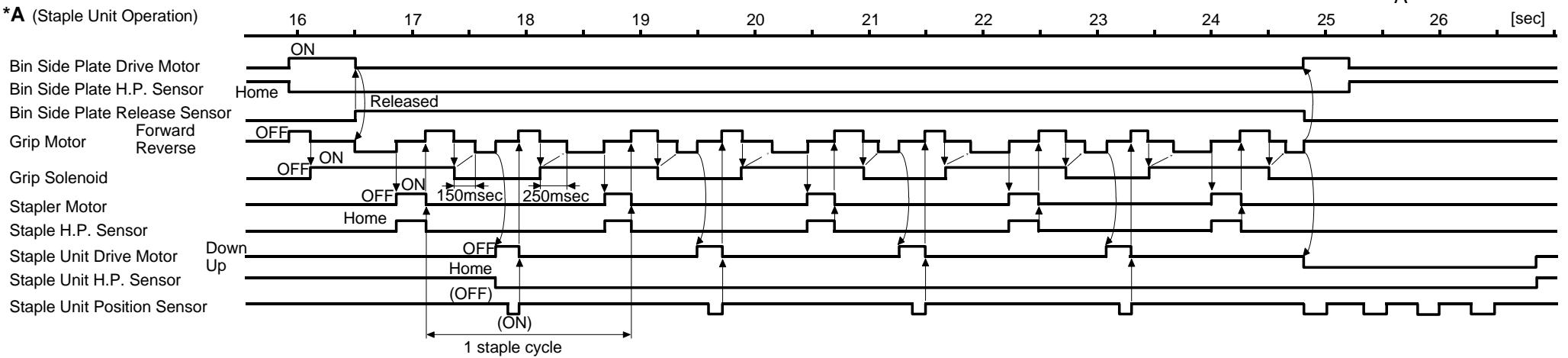



---

## 12. ACCESSORY CHECK

Check the quantity and condition of the accessories in the box according to the following list:

1. Front Connecting Bracket .....	1
2. Rear Connecting Bracket .....	1
3. Locking Bracket .....	2
4. Fixing Bracket .....	1
5. Sorter Stapler Key Sheet .....	1
6. Staple Position Decal .....	1
7. Staple Cartridge .....	1
8. Stepped Screw .....	2
9. Decal Switch .....	1
10. Philips Pan Head Screw -4 x 10 .....	2
11. Grounding Screw with Toothed Washer.....	1
12. Philips Pan Head Screw-M4 x 6 .....	6
13. Caster Stopper .....	2
14. New Equipment Condition Report (-17, -27 machines only) .....	1
15. Envelope for N.E.C.R. (-17 machine only) .....	1
16. Installation Procedure .....	1

## 13. INSTALLATION PROCEDURE

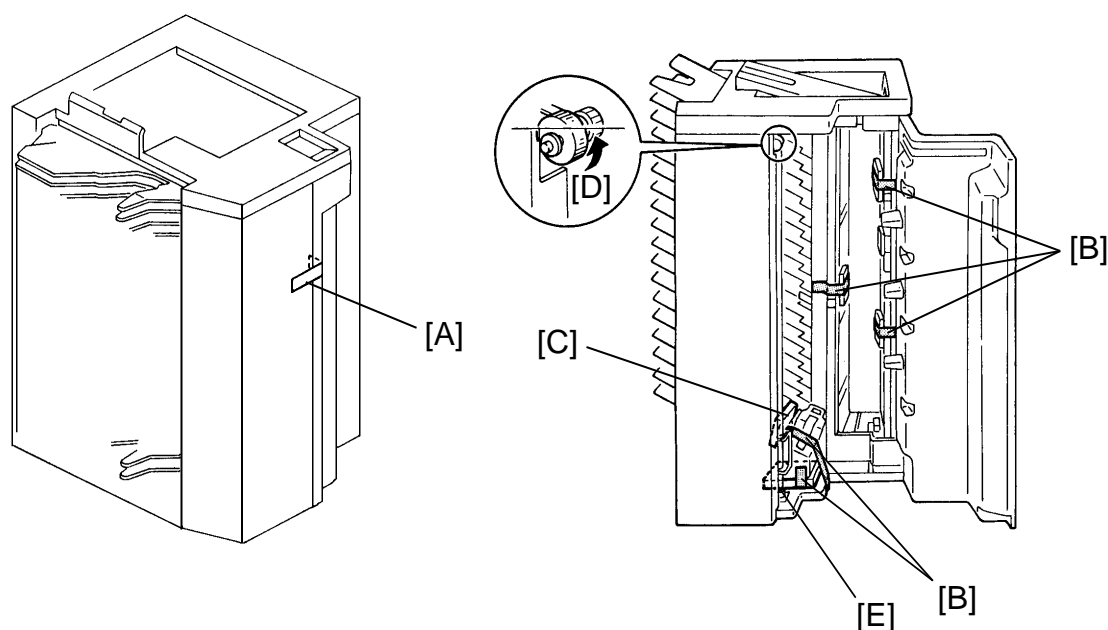

**NOTE:** The sorter adapter (A328) should be installed before the sorter stapler is.

The copier must be placed on the paper tray unit, or a table of exactly the same height, so that the copier and sorter stapler paper paths meet.

An interface PCB (A344) is also necessary.

**CAUTION: Unplug the copier power cord before starting the following procedure.**

1. Remove the strip of tape [A] on the front door.
2. Open the front door, then remove 5 strips of tape [B] and a styrofoam block [C]. Raise the staple unit by rotating the staple unit positioning knob [D] counterclockwise, then remove the sponge cushion [E] underneath.

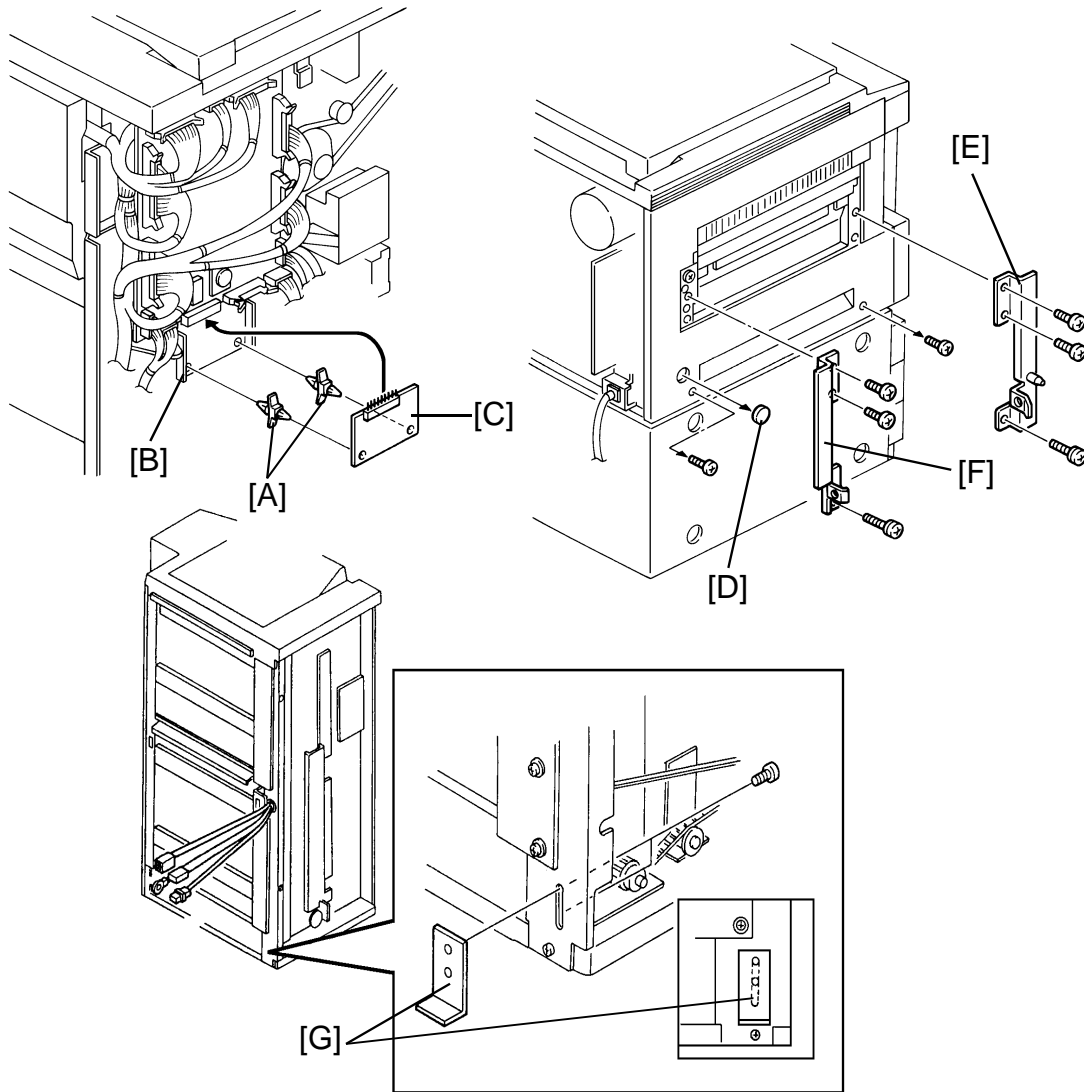

3. Remove the copier rear cover (remove 2 screws and loosen 2 screws).
4. Set the 2 locking supports [A] on the copier main board bracket [B] and install the interface PCB [C] onto CN114 on the main board as shown.
5. Remove the plastic cap [D] and two lower screws from the copier left cover as shown.
6. Install the front and rear connecting brackets [E], [F] on the copier as shown (1 long and 2 short screws each).
7. Remove the sorter stapler rear cover (remove 3 screws, loosen 1 screw).
8. For now, install the fixing bracket [G] on the sorter stapler at the lowest position (2 screws). (See step 12)



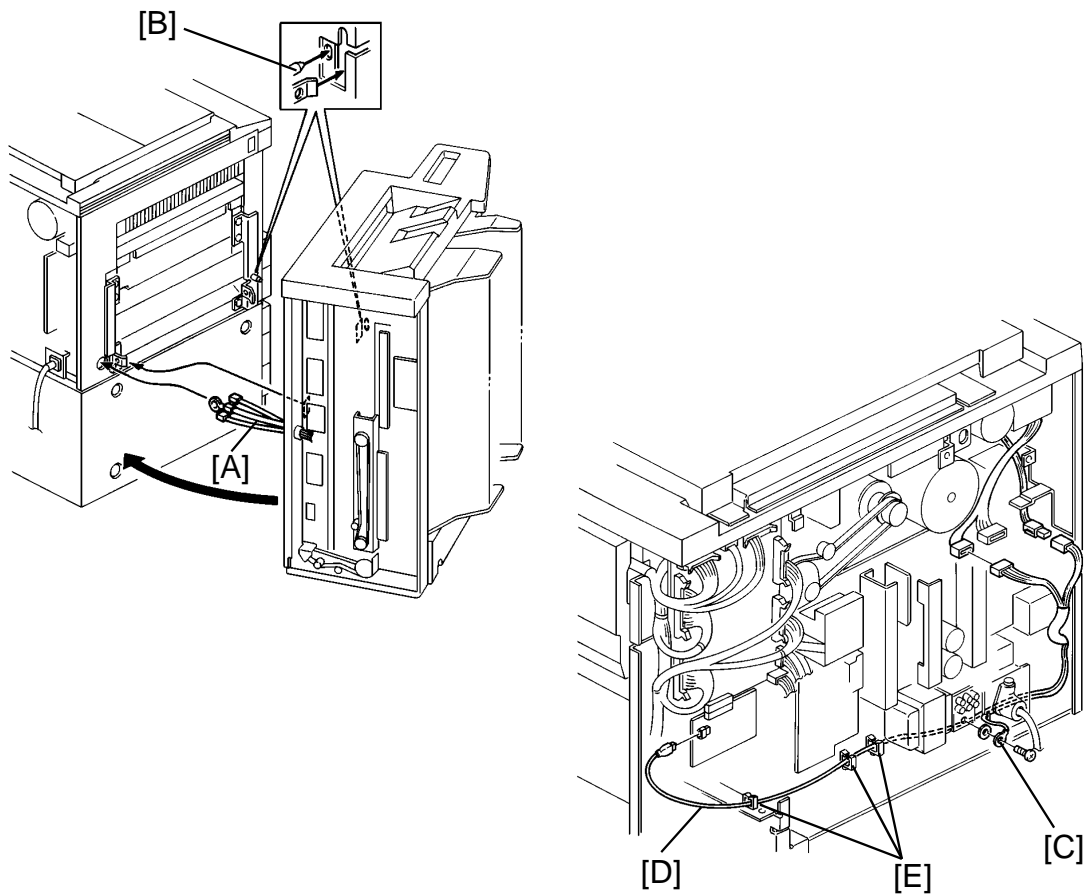

9. Pass the harnesses [A] through the access hole and connect the sorter stapler with the copier. Make sure that the stud on the front connecting bracket [B] is positioned in the sorter stapler positioning hole.

**NOTE:** Be careful not to damage the harnesses when connecting the sorter stapler with the copier.

10. Secure the protective earth wire [C] under the power cord terminal (1 grounding screw with toothed washer), and couple the 3 connectors as follows:

Sorter Stapler Connector	Copier Connector
2p (Red)	2p (Red)
4p (White)	4p (White)
2p (Fiber Optic Cable)	CN703 on the interface PCB

**NOTE:** Run the fiber optics cable [D] as shown and set it in the wire saddles [E].

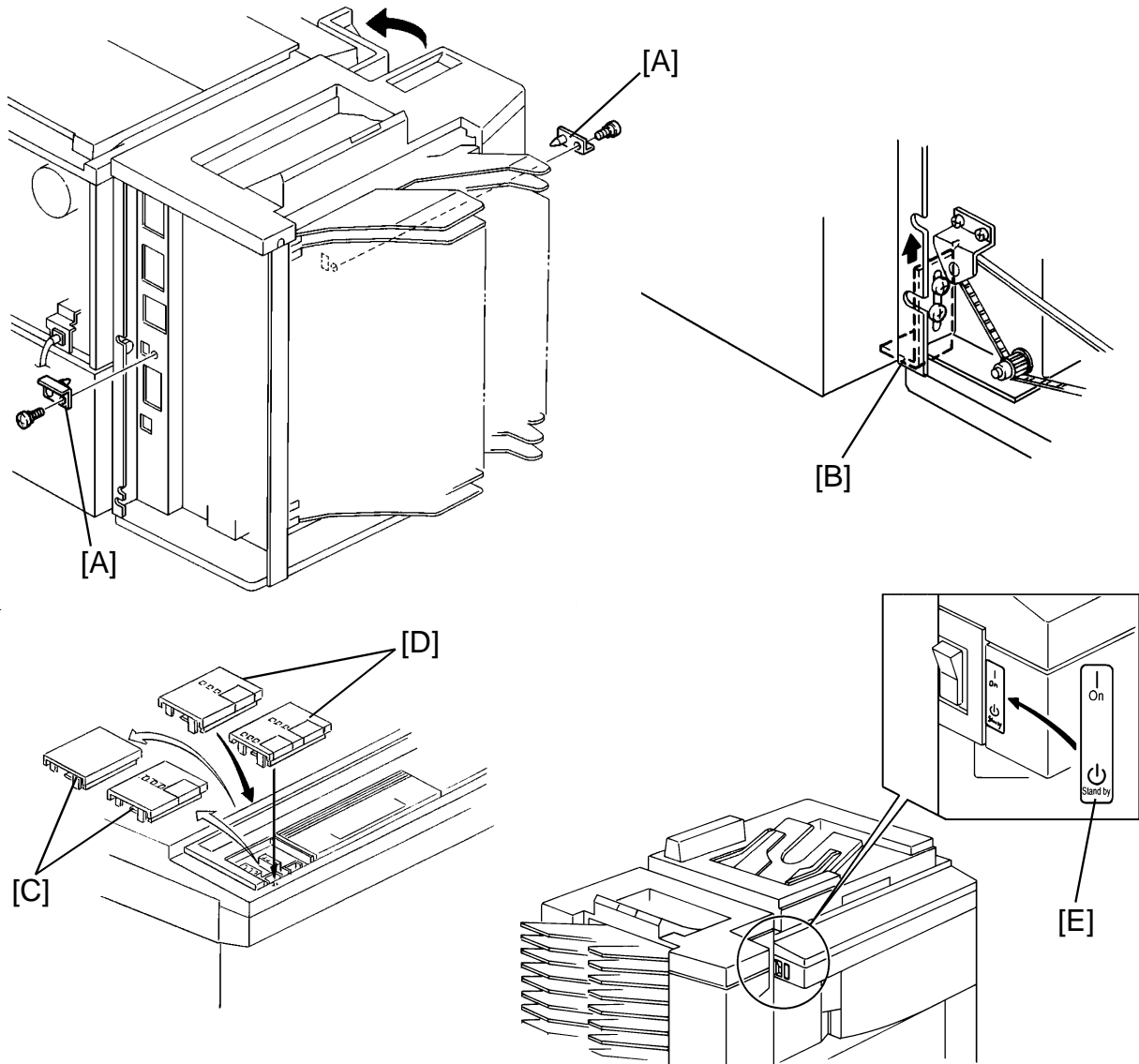

11. Install the locking brackets [A] at the front and the rear to secure the sorter stapler to the copier (1 stepped screw each).
12. Loosen the 2 screws, lift the fixing bracket [B] up against the paper tray unit base plate and retighten the screws.
13. Remove the left plastic cover [C] on the operation panel and install the sorter key top and cover [D] instead.  
(The sorter key top and cover are provided as an accessory for the copier.)
14. Stick the main switch decal [E] on the copier as shown.

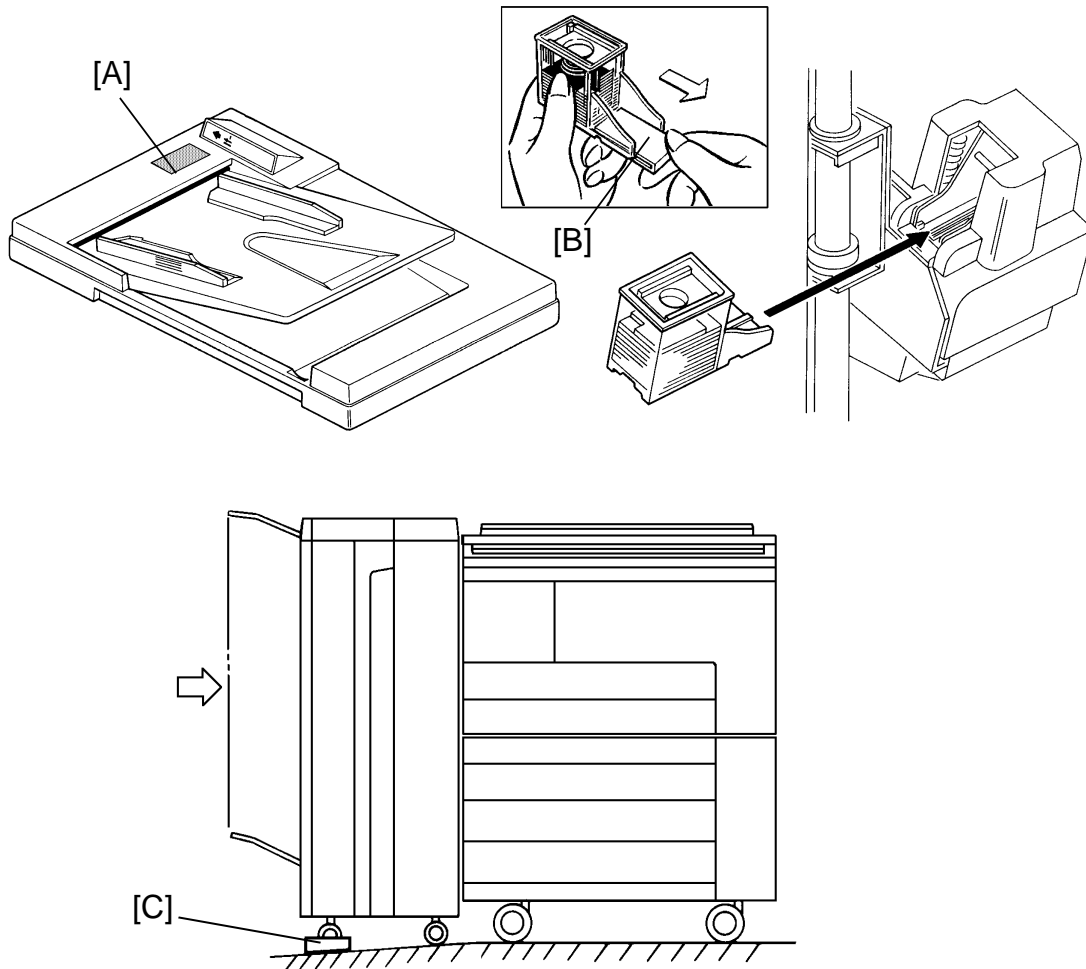

15. Stick the staple position decal [A] on the ARDF as shown. (If there is no ARDF, stick it on the corresponding position of the platen cover.)
16. Remove the green plastic clip [B] from the staple cartridge, and install the cartridge in the stapler.
17. Reinstall the covers and plug in the copier.
18. Press the sorter stapler against the copier and fix its position by placing caster stoppers [C] as shown.
19. Turn on the main switch of the copier and test the operation of the sorter stapler.

**NOTE** \* The copier recognizes automatically that the sorter stapler is installed, so it is unnecessary to set SP#71.  
 \* The stapler will not be stapling for the first 10 or so copies until the first staple comes to the proper position from the cartridge.

## 14. SERVICE TABLES (MAIN CONTROL BOARD)

### 14.1 DIP SWITCHES

#### DIP SW 100

0 : OFF

1 : ON

1	2	3	4	5	6	Function	Remarks
	0	0	0	0	0	Proof Motor Speed Adjustment 1 (350 mm/s)	#1
	1	0	0	1	0	Proof Motor Speed Adjustment 2 (300 mm/s)	#1
*	1	0	0	0	0	Sorter Free Run	#2
1	0	1	0	0	0	Staple Free Run	#3
	1	1	0	0	0	Sorter & Staple Free Run	#4
	0	0	1	0	0	Lowers Staple Unit (To 6th Bin)	
	1	0	1	0	0	Lowers Staple Unit (To 20th Bin)	
	0	1	1	0	0	Opens Bin Side Plate	
0	0	0	0	0	1	Bin/Jam Sensor Adjustment	

**NOTE: \*1** Confirm the setting from DIP SW100-2 to -6 before turning on DIP SW100-1 (Start SW function).

Turn off DIP SW100-1 to stop the function.

#### Remarks

#1: The proof motor and turn gate solenoid turn on.

Adjustment 1: For model A053

Adjustment 2: For model A069/A073/A074

#2: The main motor turns on. The bin solenoids turn on in order and the jogger motor drives the jogger plate (B5 lengthwise size) as each bin solenoid turns on.

#3: The staple unit (grip assembly and stapler) movement is repeated from the 1st to 20th bins. When there is no paper in a bin, stapling operation is skipped for that bin.

#4: #2 and #3 are repeated together.

Combinations other than those above are used only at the factory.

## 14.2 LED AND VARIABLE RESISTORS

LED NO.	VR NO.	FUNCTION
100	100	Adjusts jam sensor sensitivity.
101	101	Adjusts bin sensor sensitivity.
102	102	Adjusts proof motor speed.

## 14.3 TEST POINTS

NUMBER	FUNCTION
TP 100	GND
TP 101	+ 5 V
TP 102	+ 24 V



# 15. PREVENTIVE MAINTENANCE SCHEDULE

## 15.1 PM TABLE

C: Clean      L: Lubricate

	EM	320K	NOTE
Transport, Distribution, and Exit Rollers	C		Damp cloth
Bins	C		Damp cloth
Bin/Jam, Paper Sensors	C		Blower brush
Bushings	L		Launa oil or equivalent; if bushings generate noise.
Gears	L		Grease-501; if gears generate noise.
Worm gears	L		Heat Resisting Grease MT-78; if worm gears generate noise.
Diagonal Transport Rollers		C	Damp cloth
Diagonal Transport Stopper		C	Alcohol
Staple Unit Guide Rod, Pad	L		Launa oil

## 15.2 REGULAR PM EXPLANATION

The diagonal transport rollers and/or the diagonal transport stopper become dirty because of paper dust and toner adhering to them. This causes copies to transport incorrectly, skew, and jam. Cleaning them is required at regular intervals.

If the diagonal transport stopper mylar is deformed or damaged, copies transport incorrectly, skew, and jam. In this case, replace the mylar.

## 16. REPLACEMENT AND ADJUSTMENT

### 16.1 STAPLER REMOVAL AND REINSTALLATION

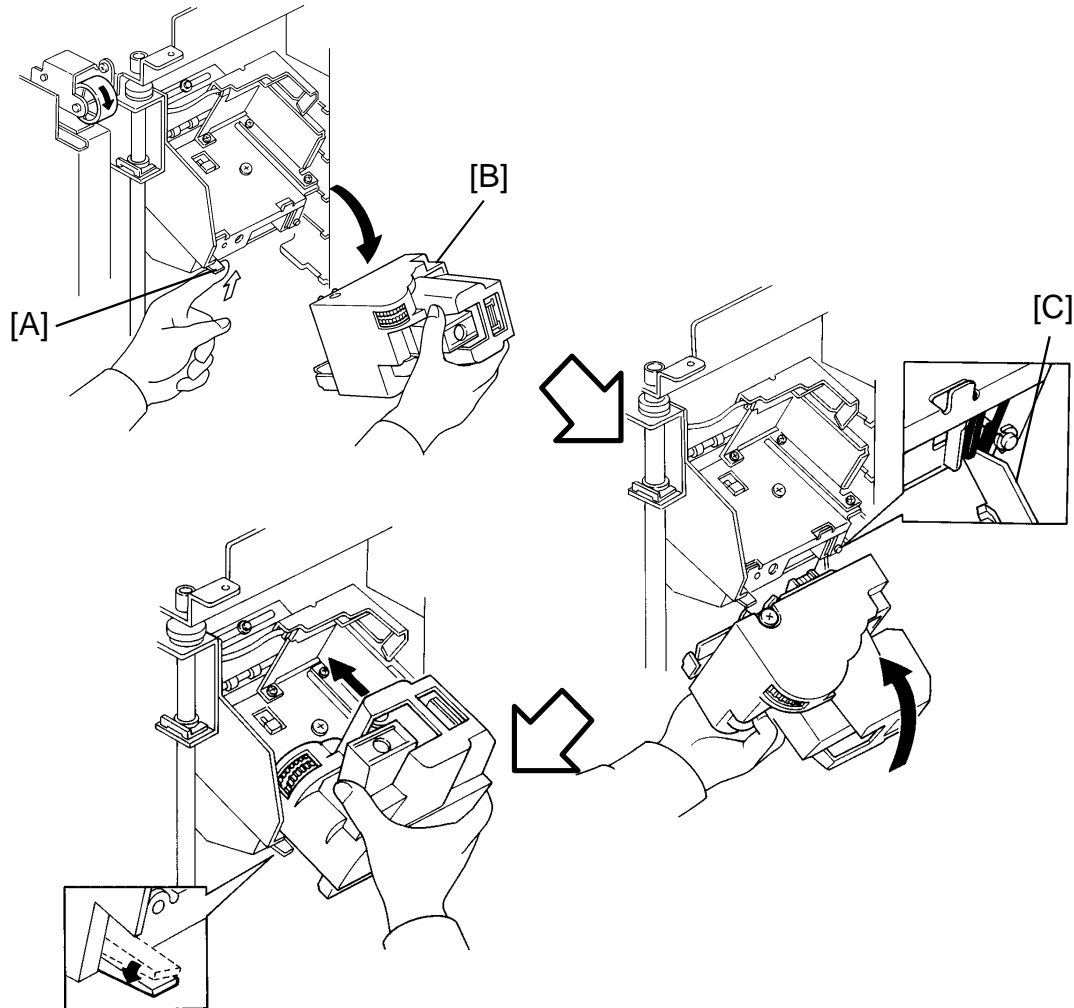

1. Open the front cover.
2. Push up the stapler release lever [A] and remove the stapler [B].
3. Reinstall the stapler.

**NOTE:** 1. The connector shutter release plate [C] should be inserted as shown.

2. Make sure that the stapler release lever is lowered to the original position after the stapler is correctly set.

## 16.2 GRIP ASSEMBLY REMOVAL AND GRIP SOLENOID ADJUSTMENT

### 16.2.1 Grip Assembly Removal

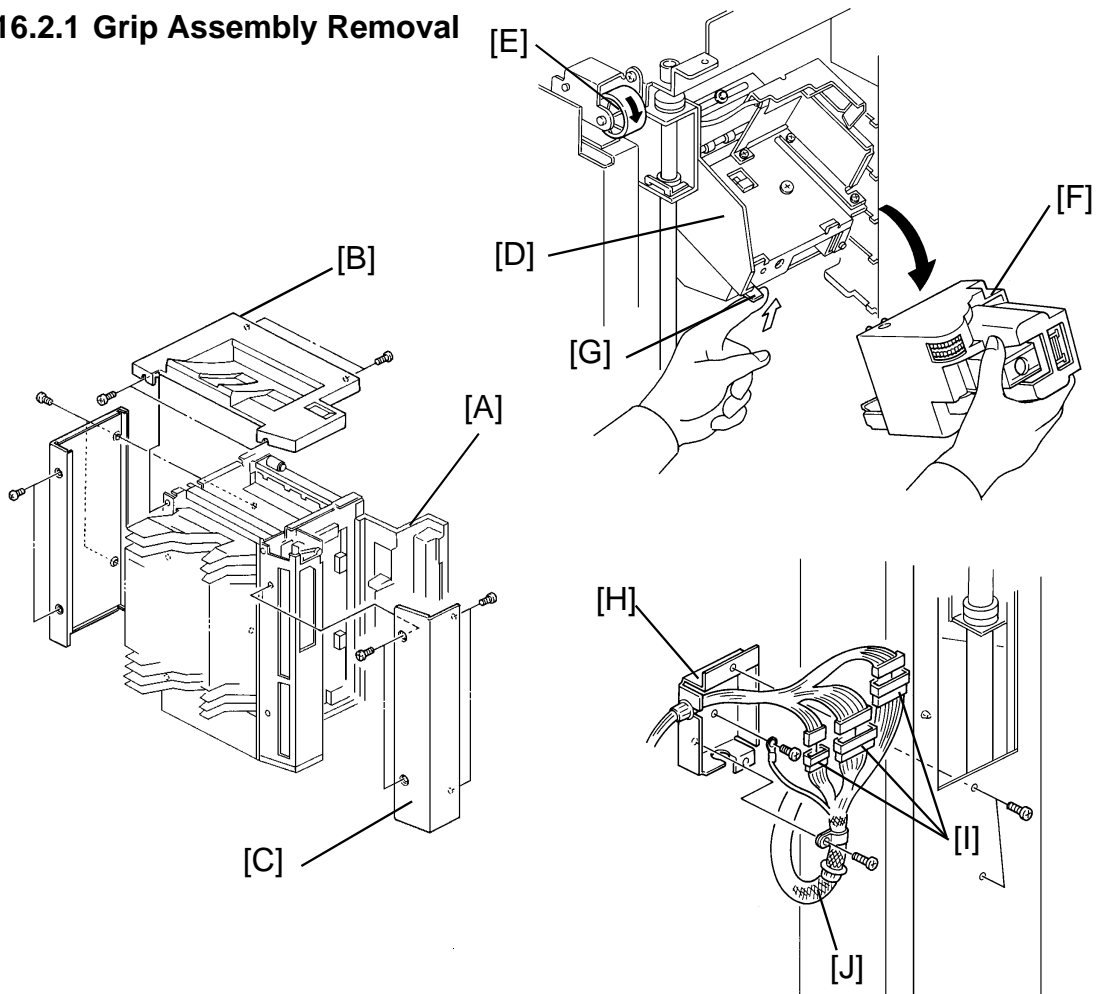

1. Open the front cover [A].
2. Remove the proof tray [B] (5 screws) and front cover [C] (4 screws).
3. Move the grip assembly [D] between the 1st bin and 7th bin by turning the knob [E].
4. Remove the stapler [F] by pressing up the stapler release lever [G].
5. Remove the frame connector cover [H] (2 screws).
6. Disconnect the 3 connectors [I] and remove the staple harness [J] (2 screws) from the frame connector cover.

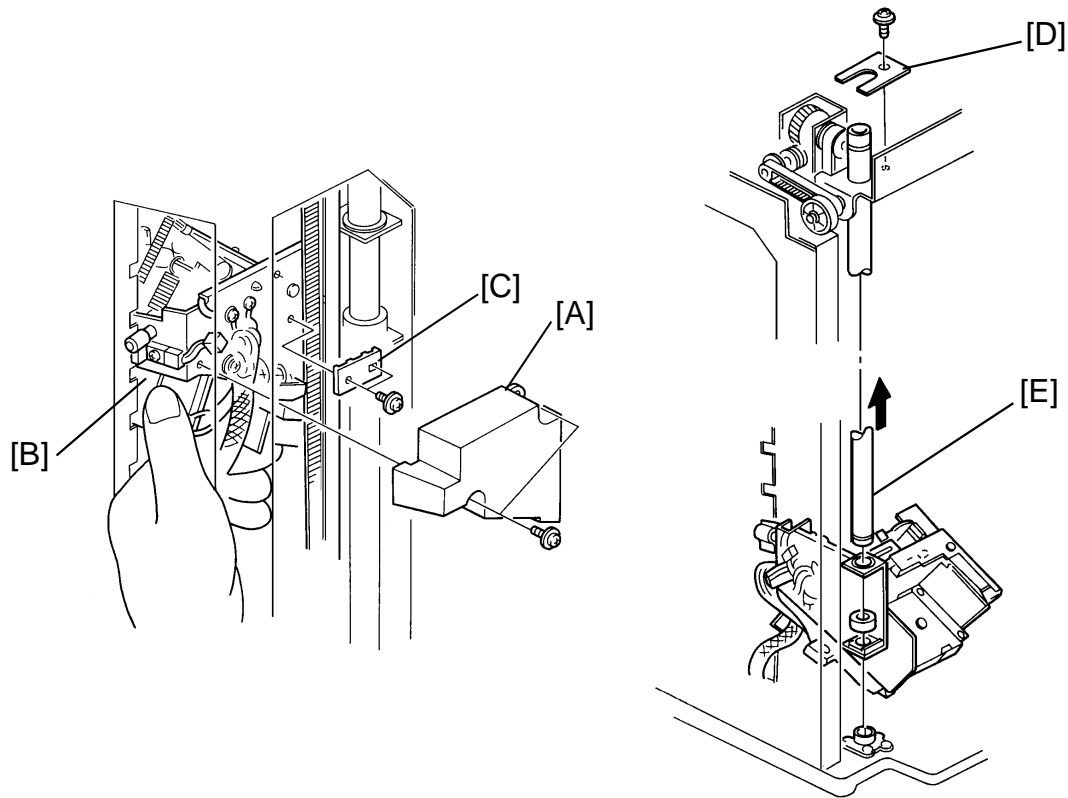

7. Remove the harness cover [A] (2 screws).
8. While holding the grip assembly [B], remove the timing belt clamp [C] (2 screws). Gently lower the grip assembly to the bottom.
9. Remove the fixing plate [D] (1 screw).
10. While holding the grip assembly, pull out the staple unit guide rod [E] from the grip assembly.

### 16.2.2 Grip Solenoid Adjustment

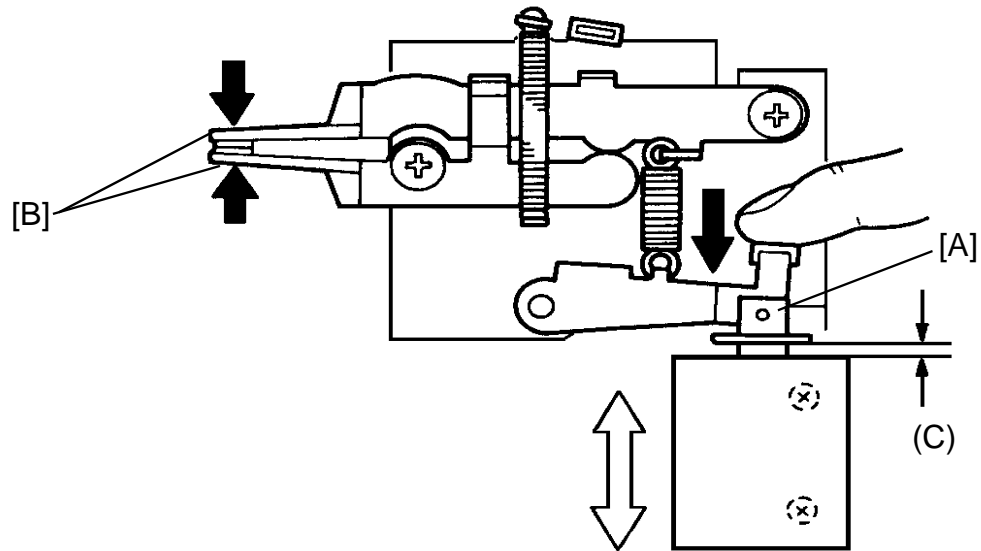

**Adjustment standard:**  $2.5 \pm 0.5$  mm

1. Remove the grip assembly (see the grip assembly removal).
2. Adjust the gripper solenoid stroke (2 screws).  
When the solenoid plunger [A] is pressed so that the gripper arms [B] touch each other, the gap (C) should be  $2.5 \pm 0.5$  mm.

### 16.3 DIAGONAL TRANSPORT STOPPER MYLAR REPLACEMENT

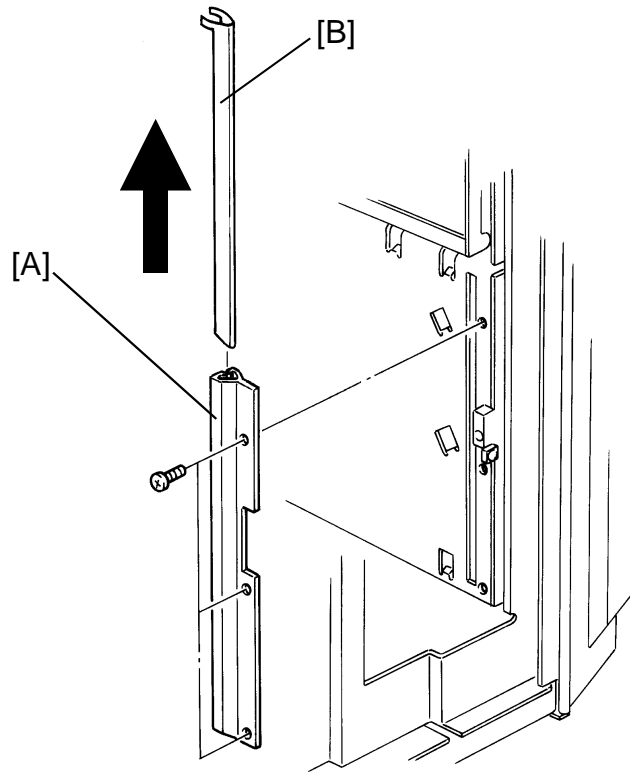

1. Open the front door.
2. Release the transport plate.
3. Remove the diagonal transport stopper [A] (3 screws).
4. Slide out the mylar [B] from the diagonal transport stopper as shown.

## 16.4 JOGGER PLATE REMOVAL AND REINSTALLATION

### 16.4.1 Jogger Plate Removal

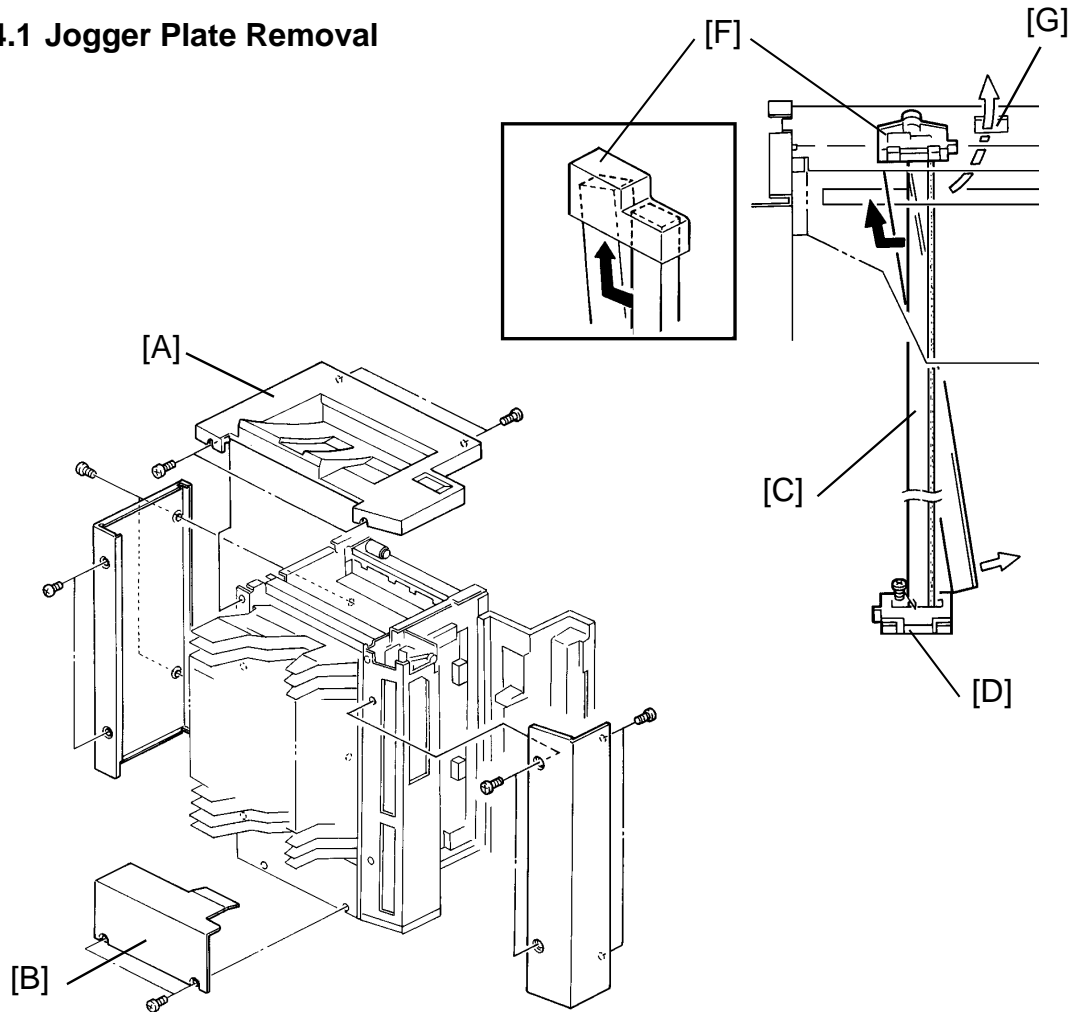

1. Remove the proof tray [A] (5 screws) and the bottom cover [B] (2 screws).
2. Push the upper part of the jogger plate [C] to the left and hold it.
3. After that, pull the jogger plate up and hold it.
4. Swing the jogger plate out of the bottom holder [D], and gently let the jogger plate fall out of the upper holder [F].
5. Pull the jogger plate out through the stay hole [G].

### 16.4.2 Jogger Plate Reinstallation

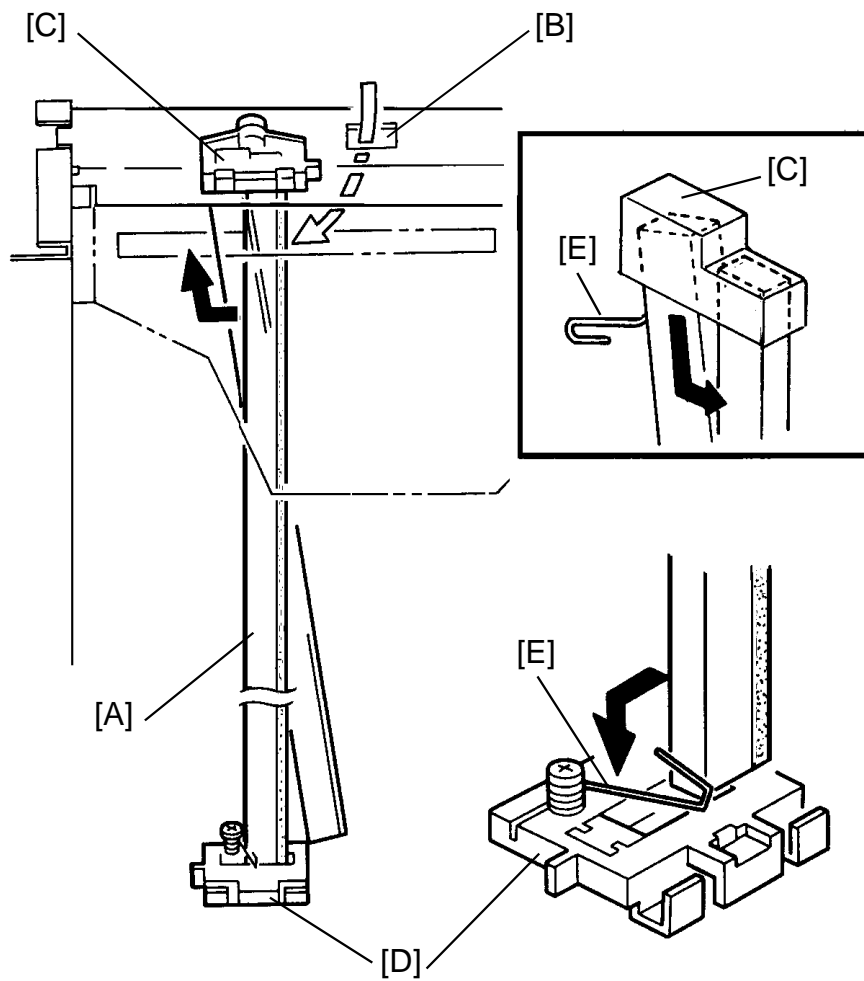

1. Insert the jogger plate [A] through the stay hole [B].
2. Insert the jogger plate into the hole of the upper holder [C] as shown and hold it.
3. Position the jogger plate at the lower holder [D].

**NOTE:** The pressure springs [E] should be placed as shown.



## 16.5 BIN REMOVAL

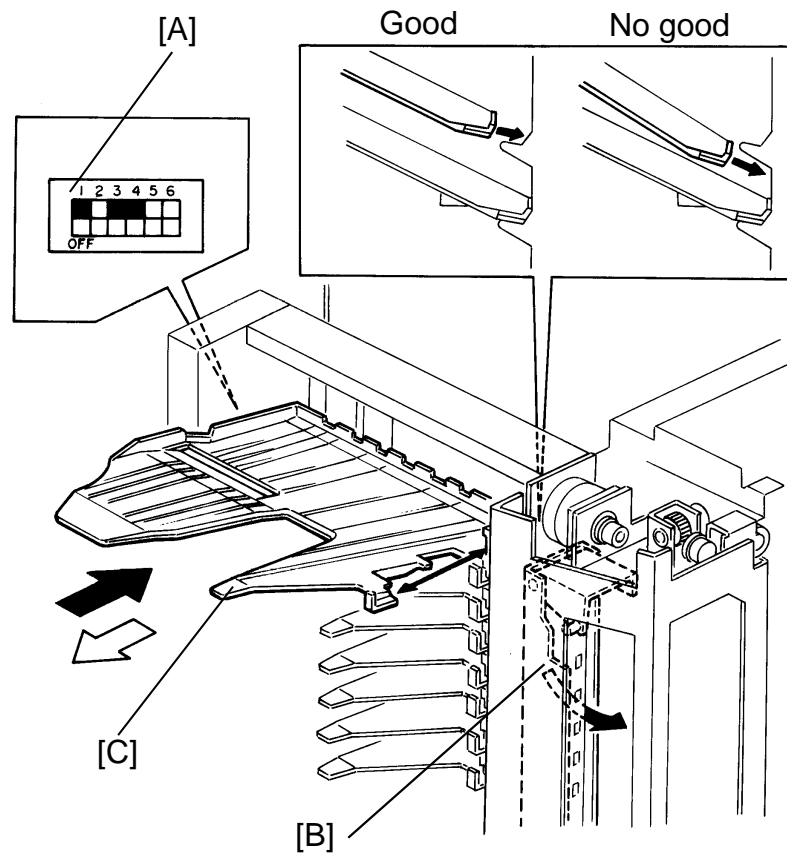

1. Remove the front and rear covers (4 screws each).
2. Remove the jogger plate (see jogger plate removal).
3. Turn on the main switch.
4. Turn on DIP SW100-3, -4 and -1 [A]. Make sure you turn on the switches in that order.
5. When the bin side plate [B] is released, turn off the main switch.
6. Pull out the sorting bins [C].

- NOTE:**
1. The 10th and 20th bins do not have an antistatic brush.
  2. When reinstalling the bins be sure that the bins are positioned correctly as shown.
  3. After reinstalling the bins, turn off DIP SW100-1, -3 and -4.

## 16.6 TRANSPORT PLATE REMOVAL

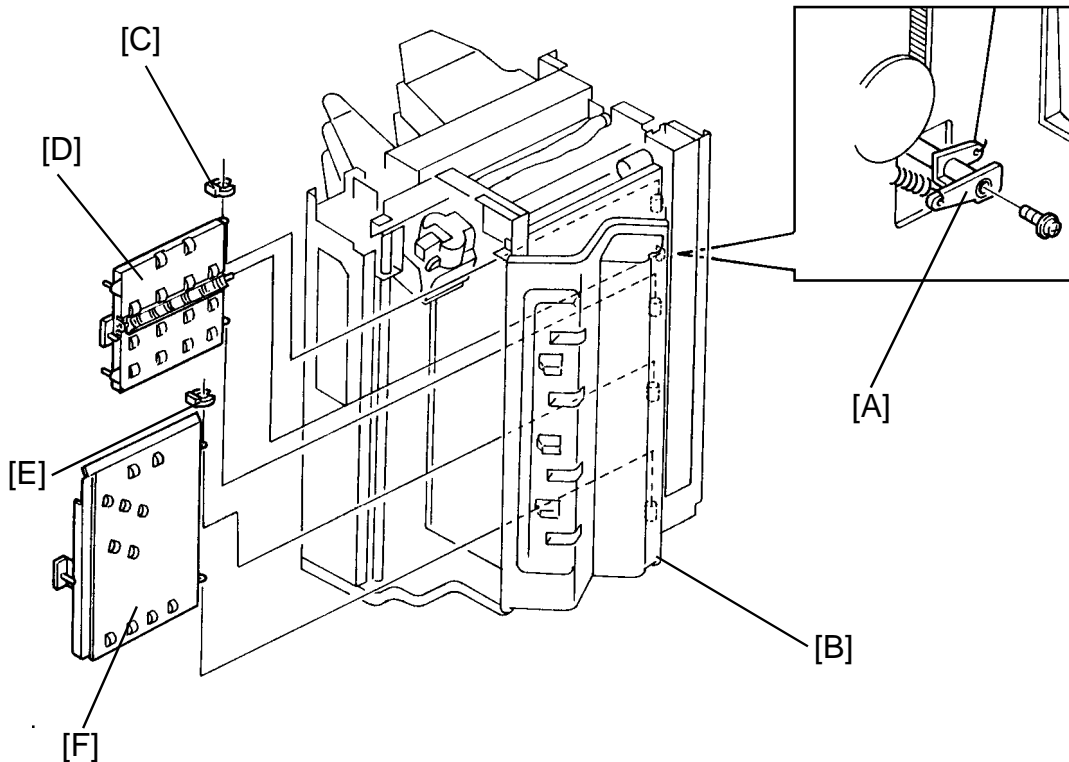

### 16.6.1 Vertical Transport Plate Removal

1. Remove the rear cover (4 screws).
2. Remove the turn gate lever [A] (1 screw).
3. Open the front door [B].
4. Remove the snap ring [C], then lift and remove the vertical the transport plate [D].

### 16.6.2 Diagonal Transport Plate Removal

1. Open the front cover [B].
2. Remove the snap ring [E], then lift and remove the diagonal transport plate [F].

### 16.6.3 Distribution Transport Plate Removal

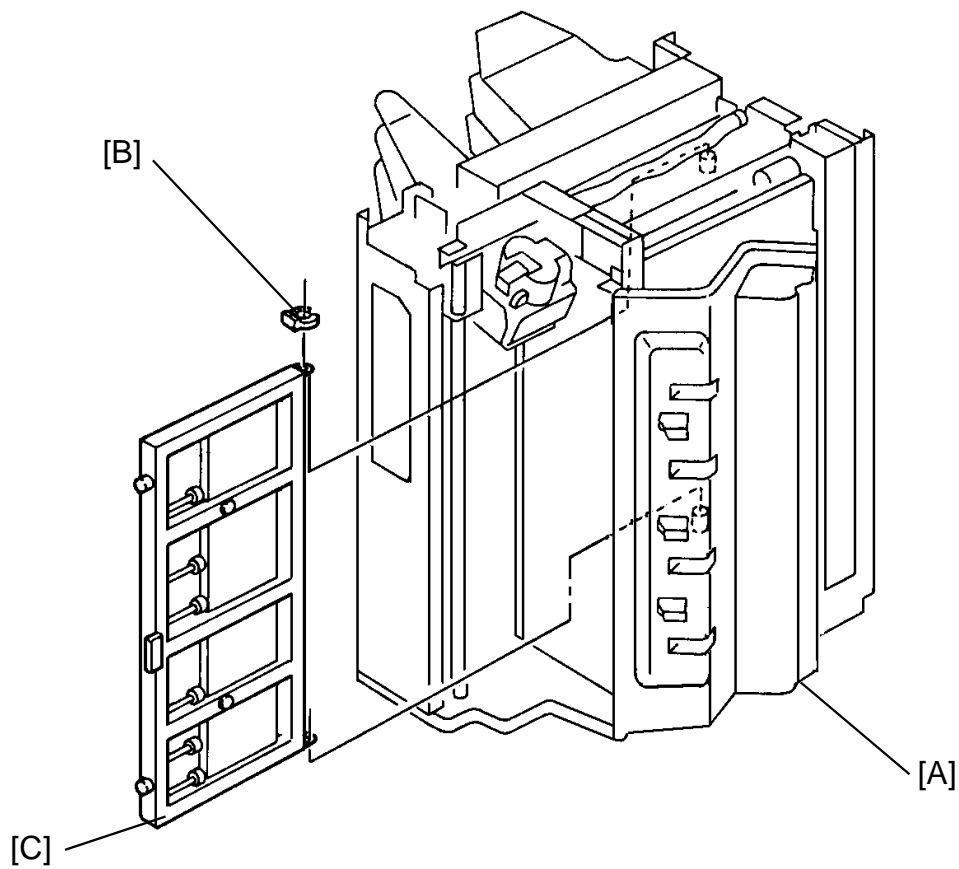

1. Open the front cover [A].
2. Remove the snap ring [B].
3. Lift and remove the distribution transport plate [C].

## 16.7 VERTICAL TRANSPORT UNIT REMOVAL

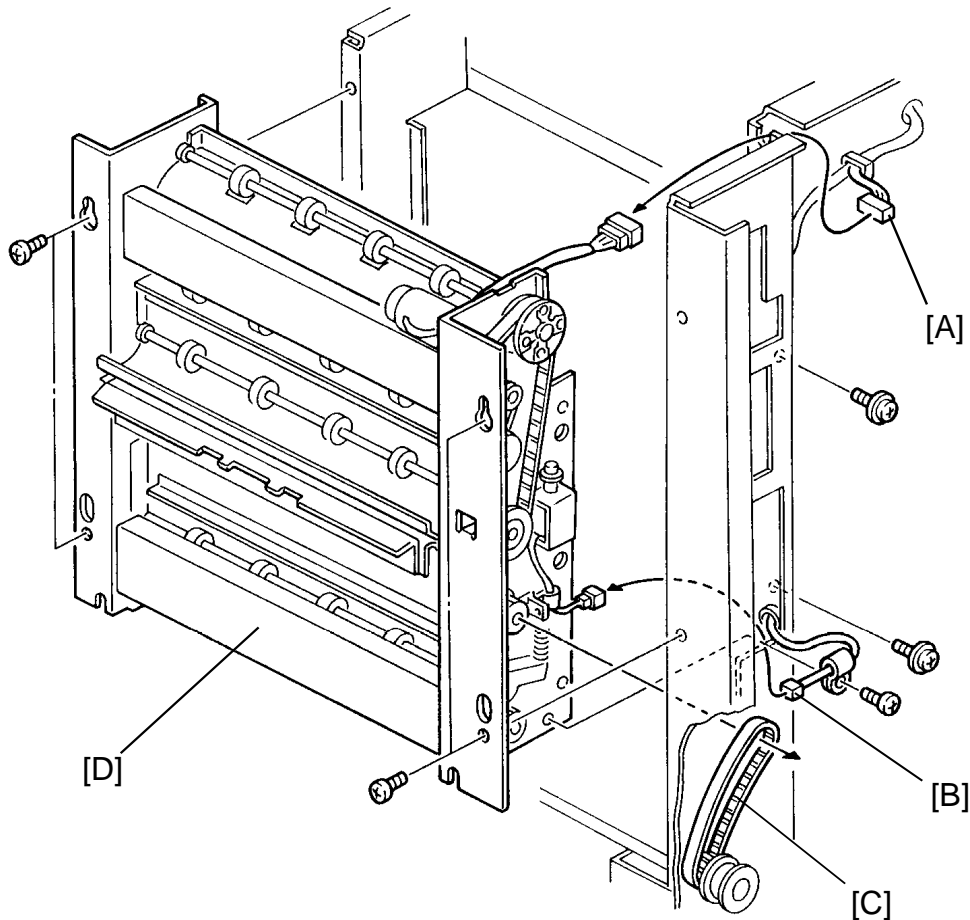

1. Remove the proof tray (5 screws) and the rear cover (4 screws).
2. Disconnect the proof motor/exit sensor connector [A] and the turn gate solenoid connector [B].
3. Loosen the timing belt [C].
4. Remove the vertical transport unit [D] (6 screws, and 1 screw for the harness clamp).

## 16.8 DIAGONAL TRANSPORT UNIT REMOVAL

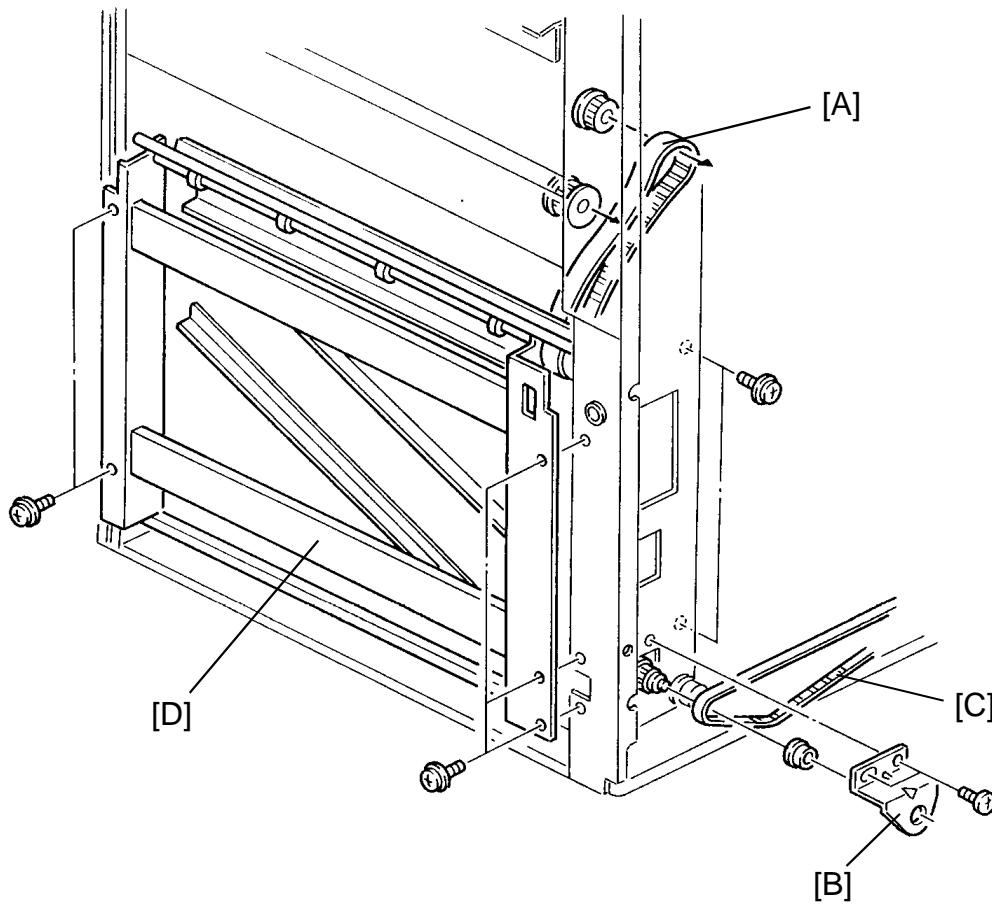

1. Remove the rear cover (4 screws).
2. Remove the timing belt [A].
3. Remove the support bracket [B] (2 screws) and the timing belt [C].
4. Remove the diagonal transport unit [D] (7 screws).

### 16.9 BELT TENSION ADJUSTMENT

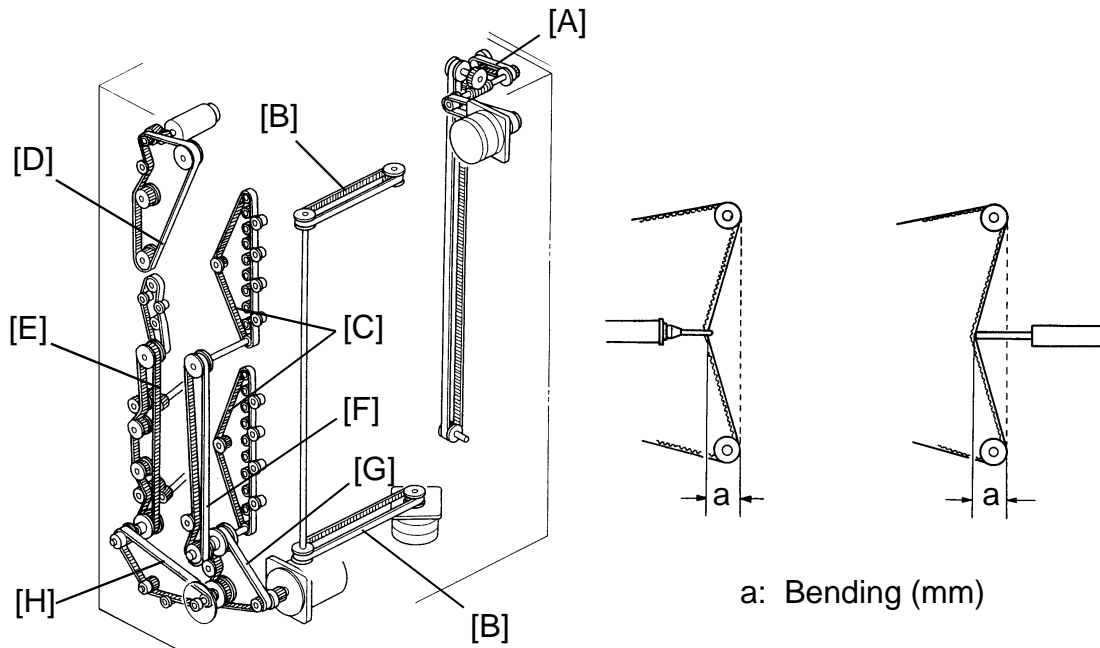

a: Bending (mm)

1. Remove the respective covers for the following belt tension adjustment:

- Timing Belt [A] ..... Proof Tray
- Timing Belt [B] ..... Proof Tray  
Bottom Cover
- Timing Belt [D] ..... Rear Cover
- Timing Belt [G] ..... Rear Cover
- Timing Belt [C] ..... Rear Cover
- Timing Belt [C] ..... Rear Cover
- Timing Belt [E] ..... Rear Cover
- Timing Belt [H] ..... Rear Cover
- Timing Belt [G] ..... Rear Cover

2. Adjust the timing belt tension as follows:

Timing Belt	Bending	Pressure
A	4 mm	200±50 g
B	5 mm	50±20 g
C	5 mm	140±40 g
D	8 mm	100±50 g
E	8 mm	100±50 g
F	6 mm	100±50 g
G	5 mm	200±50 g
H	6 mm	100±50 g

## 16.10 MAIN CONTROL BOARD REPLACEMENT AND ADJUSTMENT

### 16.10.1 Main Control Board Replacement

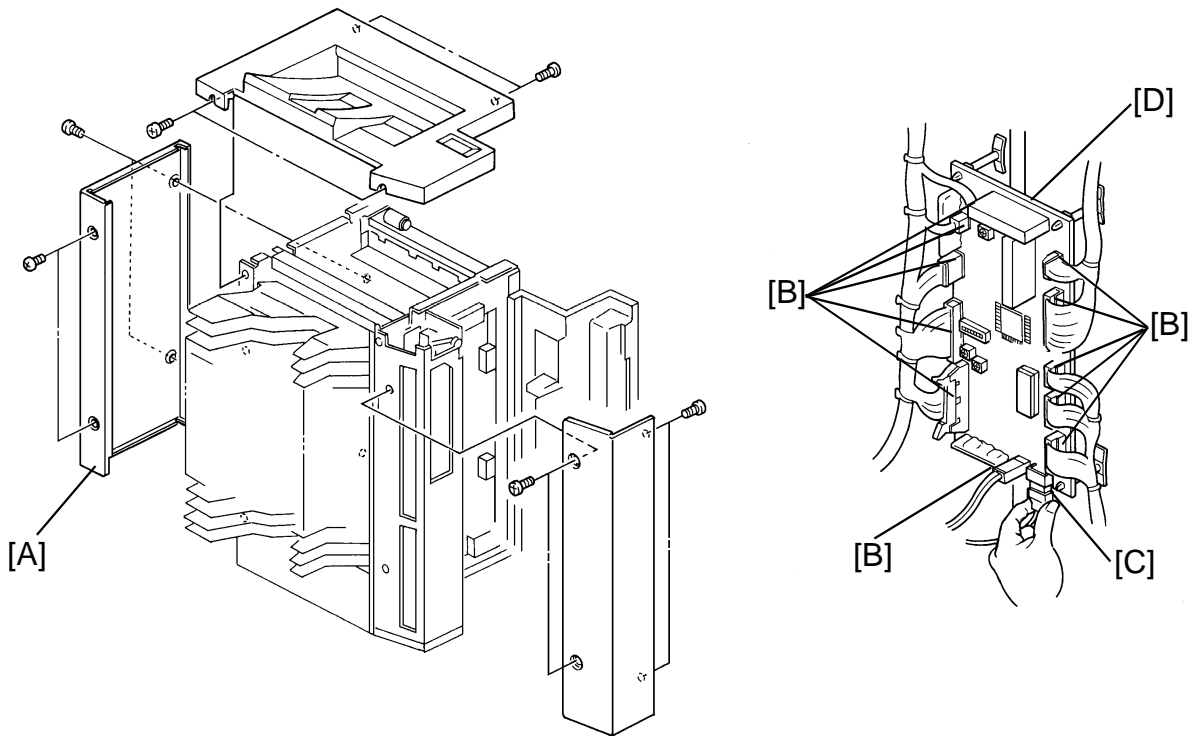

1. Remove the rear cover [A] (4 screws).
2. Disconnect the main control board connectors [B] and fiber cable [C].  
**NOTE:** When disconnecting the fiber cable, do not pull it by the cable, but by the connector.
3. Replace the main control board [D] and connect the connectors.
4. Turn on the main switch.
5. Adjust the proof motor speed and bin/jam sensors (see next two pages).
6. Turn off the main switch.

### 16.10.2 Proof Motor Speed Adjustment

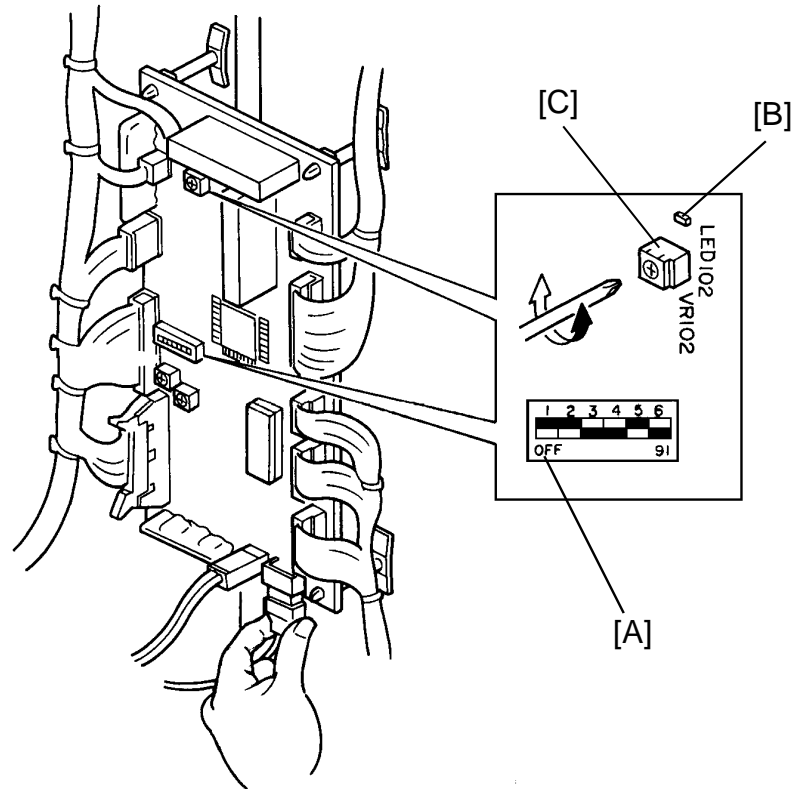

1. Turn on DIP SW100-2, 5 [A].
2. Turn on DIP SW100-1.
3. If LED102 [B] is on, turn VR102 [C] counterclockwise until LED102 turns off.
4. Turn VR102 clockwise until LED102 starts blinking and go on turning until it is continuously on.
5. Turn off DIP SW100-1, -2, -5.

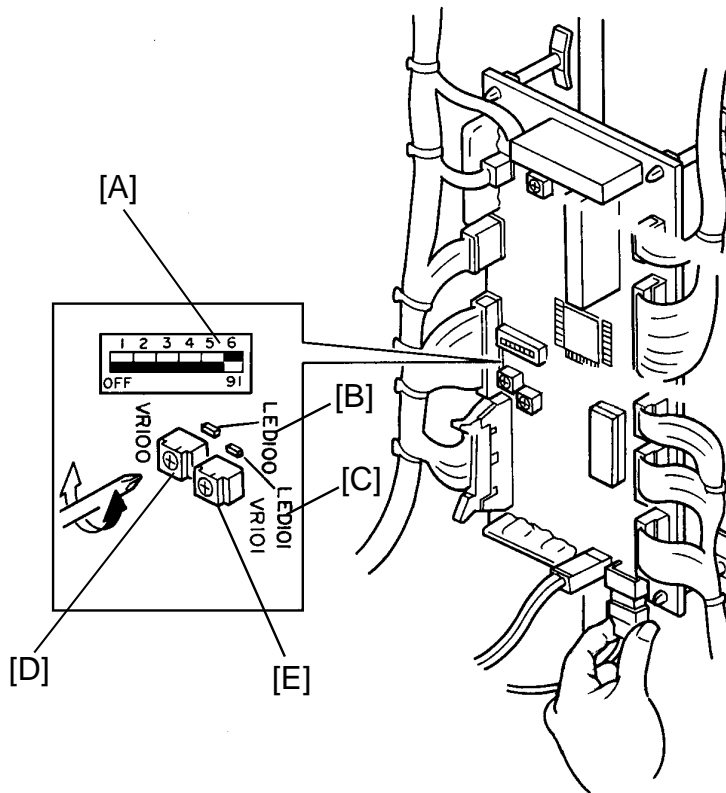

**16.10.3 Bin/Jam Sensor Adjustment**

1. Turn on DIP SW 100-6 [A].
2. If LED100 [B] and LED101 [C] are on, turn VR100 [D] and VR101 [E] clockwise until LED100 and LED101 turn off.
3. Turn VR100 and VR101 counterclockwise until LED100 and LED101 start blinking and go on turning until they are continuously on.
4. Turn off DIP SW 100-6.

## 16.11 MAIN MOTOR REPLACEMENT

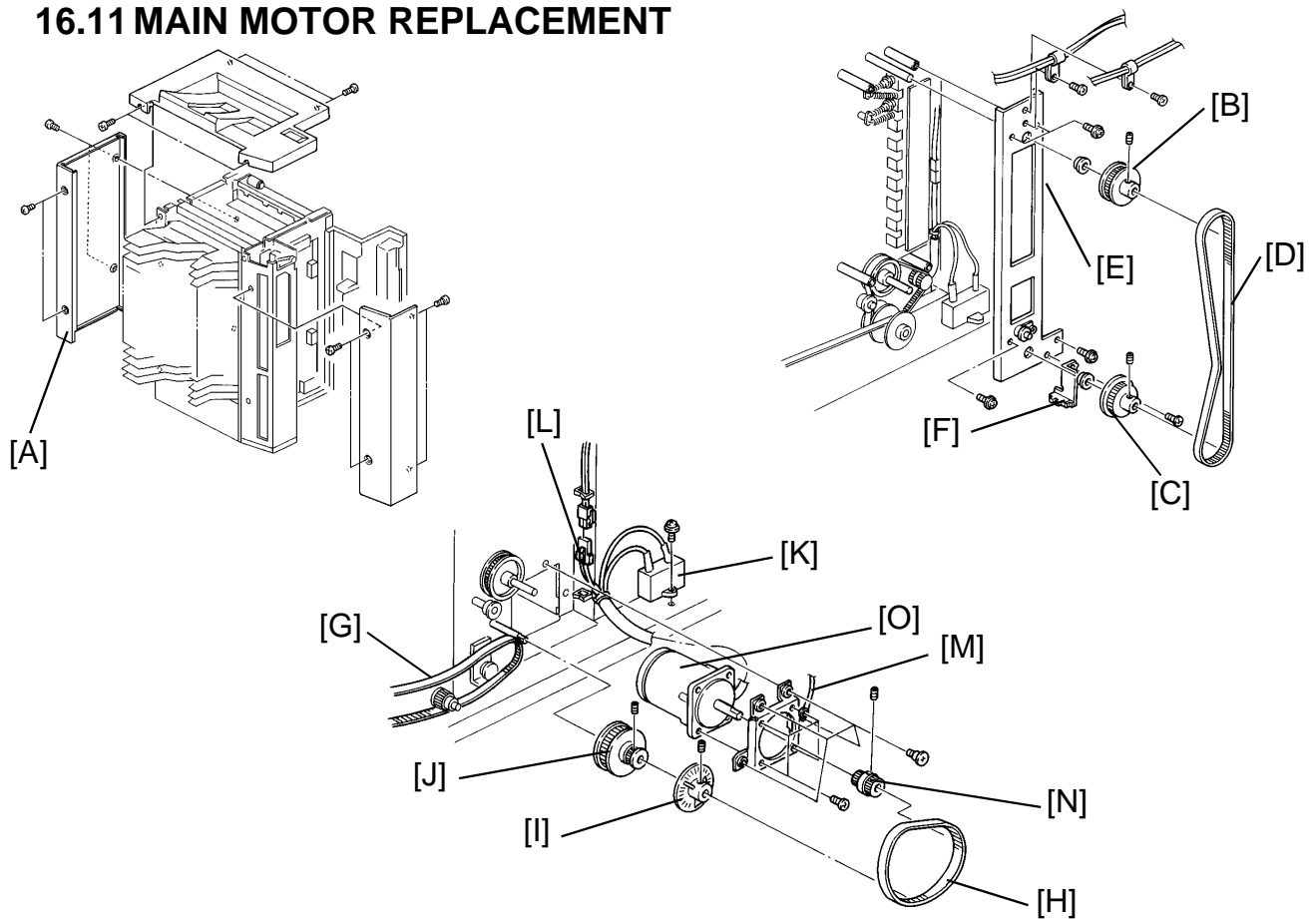

1. Remove the rear cover [A] (4 screws).
2. Remove the timing pulleys [B, C] (1 Allen screw each) and timing belt [D].
3. Remove the support bracket [E] (4 screws, and 2 screws for the harness clamps).
4. Remove the timing sensor bracket [F] (1 screw).
5. Loosen the timing belt and remove the timing belts [G, H].
6. Remove the disk [I] and the timing pulley [J] (1 Allen screw each).
7. Remove the capacitor [K] (1 screw) and disconnect the main motor harness [L].
8. Remove the grounding wire [M] (1 screw) and the main motor assembly (4 stepped screws).
9. Remove the timing pulley [N] (1 Allen screw) and replace the main motor [O] (3 screws).

**NOTE:** The timing pulley is used for both the 50 Hz and 60 Hz machines.  
 50 Hz: 18T                      60 Hz: 14T

---

## 17. SERVICE CALL CONDITIONS

### 17.1 CODE # H1 – PROOF MOTOR ERROR

#### - Definition -

When the proof motor is turning, the encoder pulse takes over 250 msec to change.

#### - Possible Causes -

- The proof motor is defective
- The main control board is defective

#### - Action -

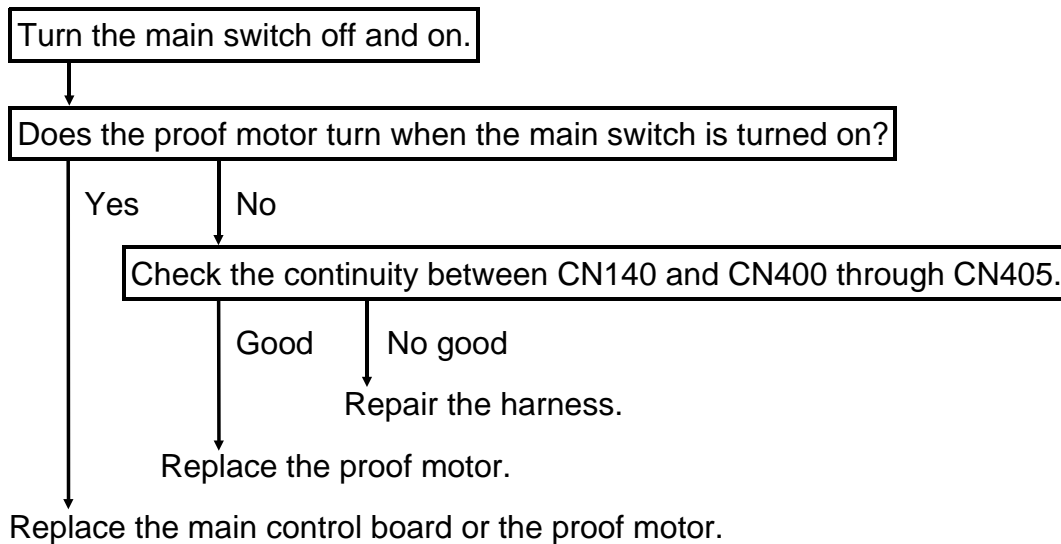

## 17.2 CODE # H2 – TIMING SENSOR OUTPUT ERROR

### - Definition -

When the main motor is turning, the timing sensor output takes over 100 msec to change.

### - Possible Causes -

- The timing sensor is defective
- The main motor is defective
- The main control board is defective

### - Action -

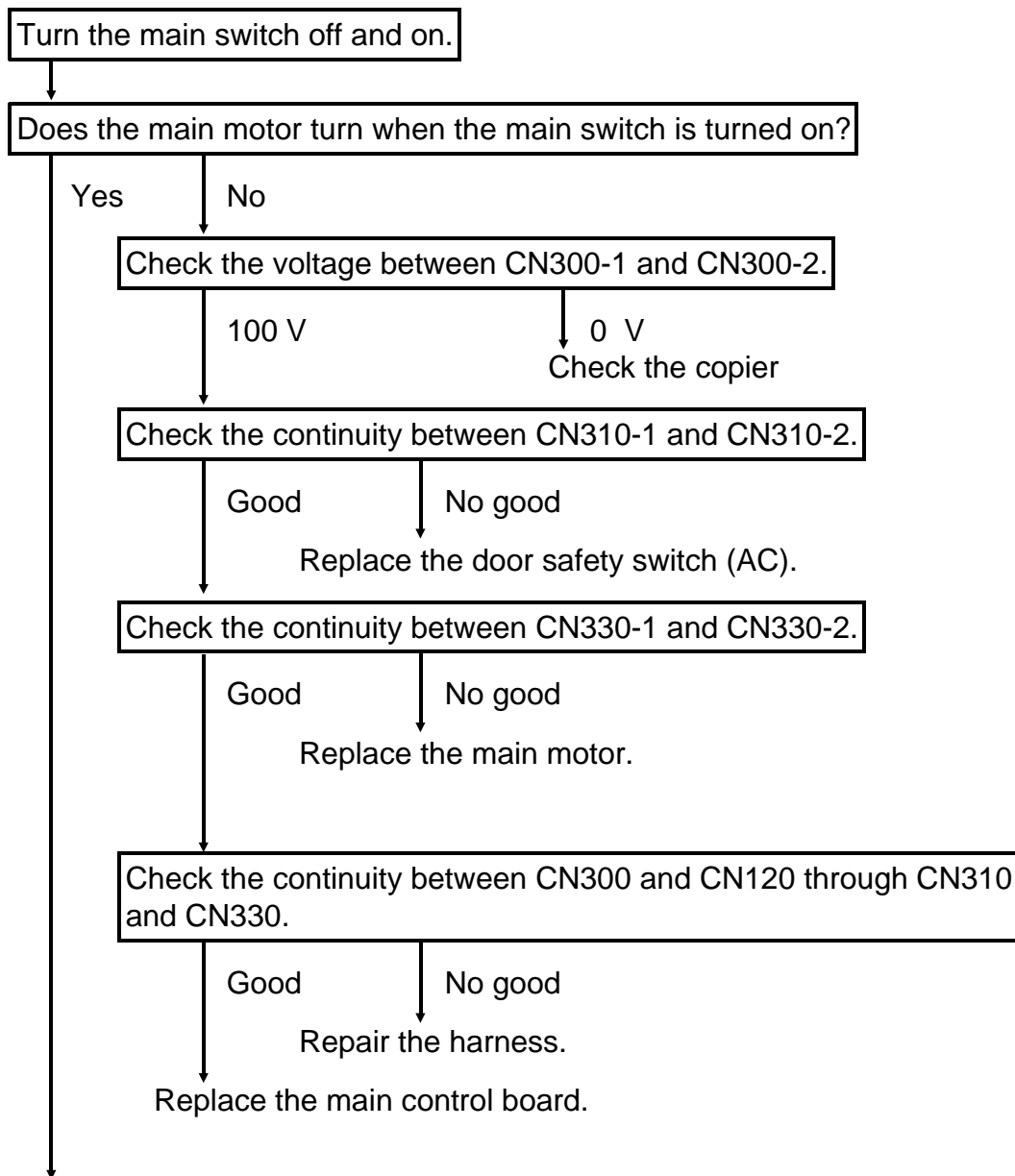

Sorter Stapler

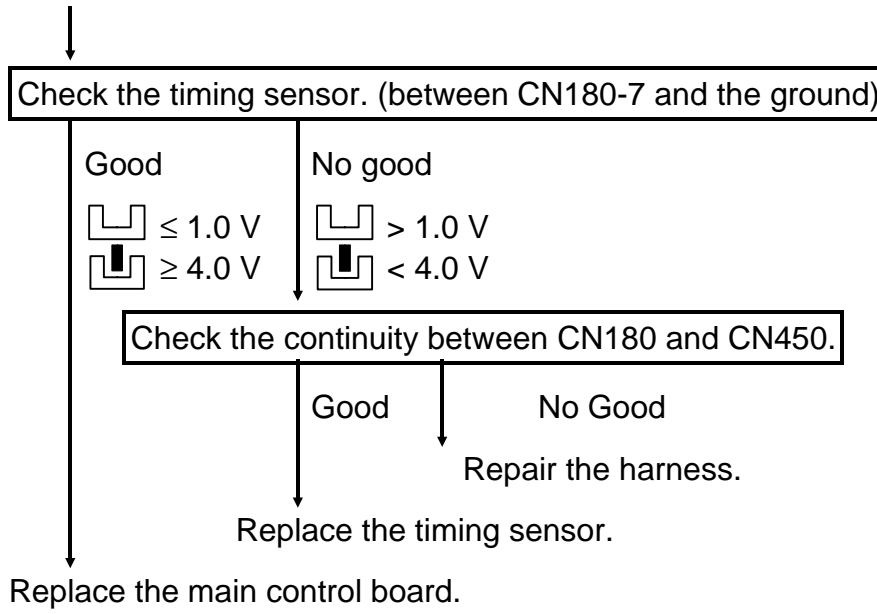

### 17.3 CODE # H3 – JOGGER H.P. SENSOR OUTPUT ERROR

#### - Definition -

- When the jogger plate moves forward, the home position sensor takes over 150 msec to turn off.
- When the jogger plate moves backward, the home position sensor takes over 1 sec to turn on.

#### - Possible Causes -

- The jogger H.P. sensor is defective
- The jogger motor is defective
- The main control board is defective
- The timing belt is not fixed

#### - Action -

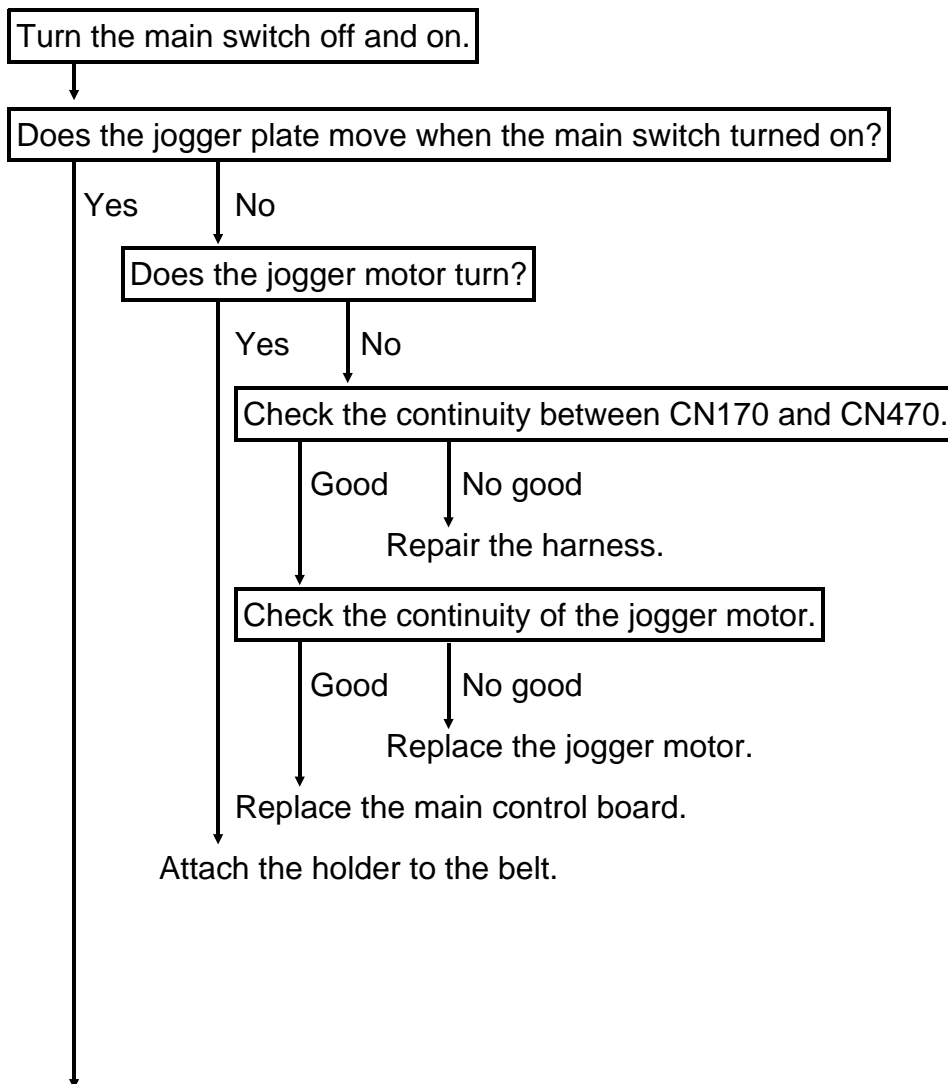

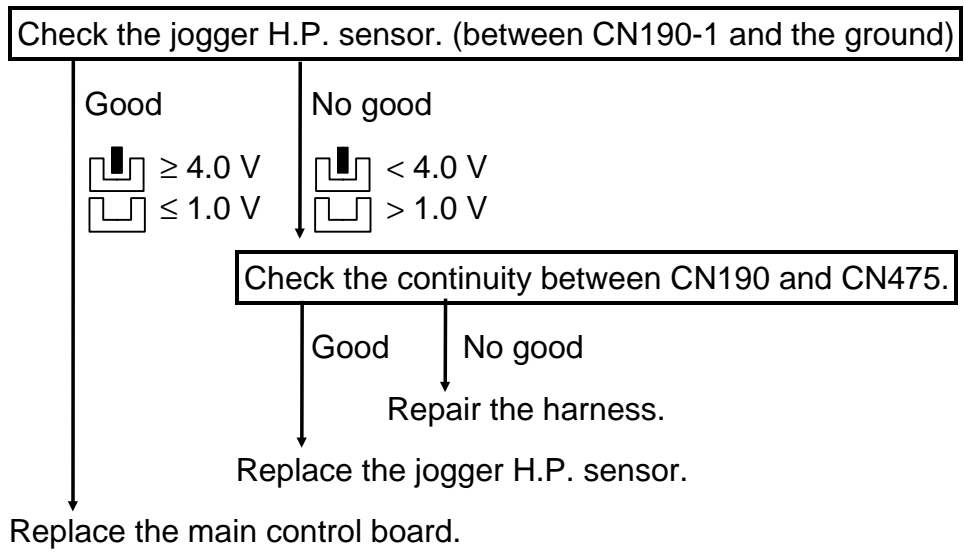

### 17.4 CODE # H4 – STAPLE UNIT POSITION ERROR

**- Definition -**

When the staple unit lowers to the next bin, the staple unit position sensor stays on for more than 1 sec or stays off for more than 500 msec.

**- Possible Causes -**

- The staple unit H.P. sensor is defective
- The staple unit position sensor is defective
- The staple unit drive motor is defective
- The main control board is defective

**- Action -**

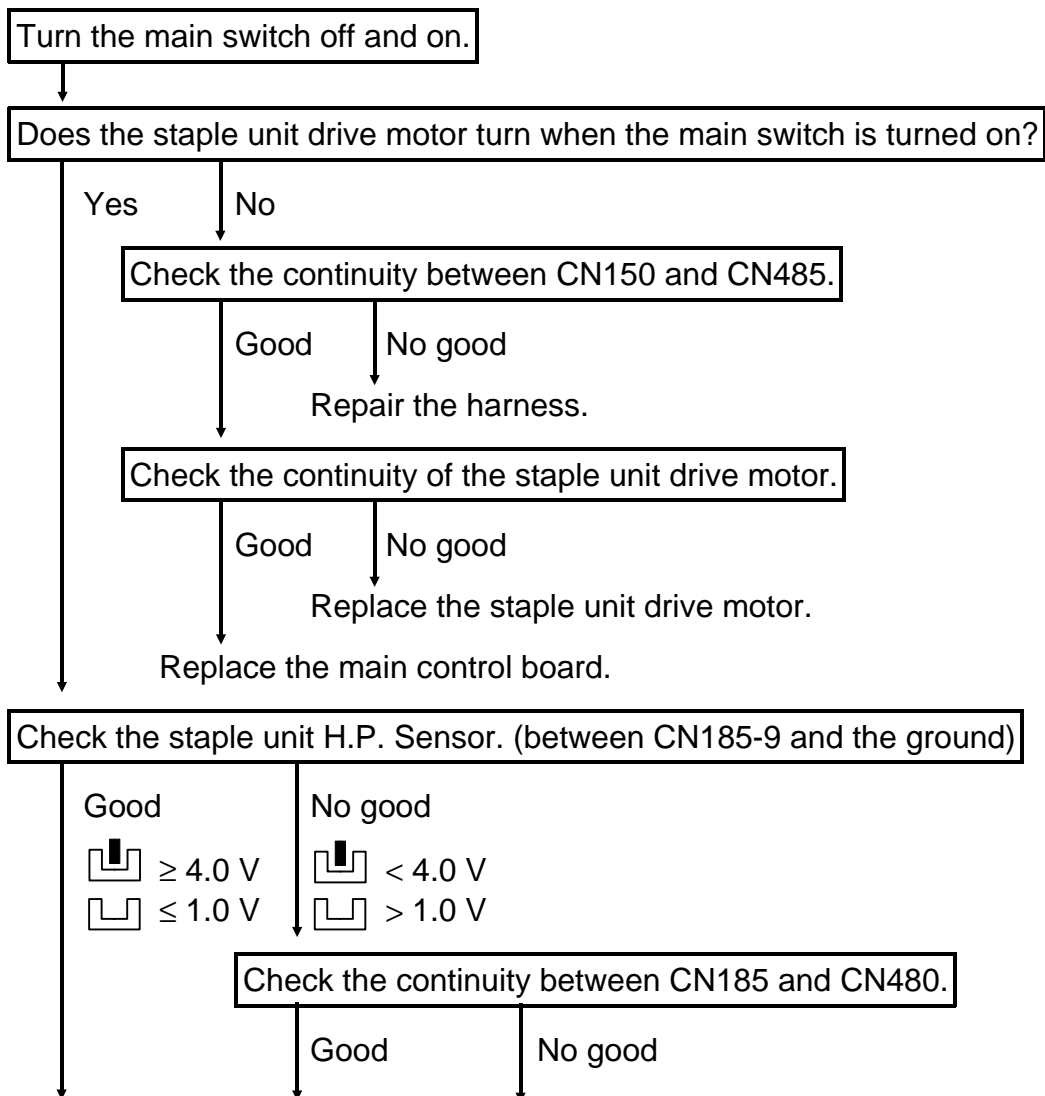



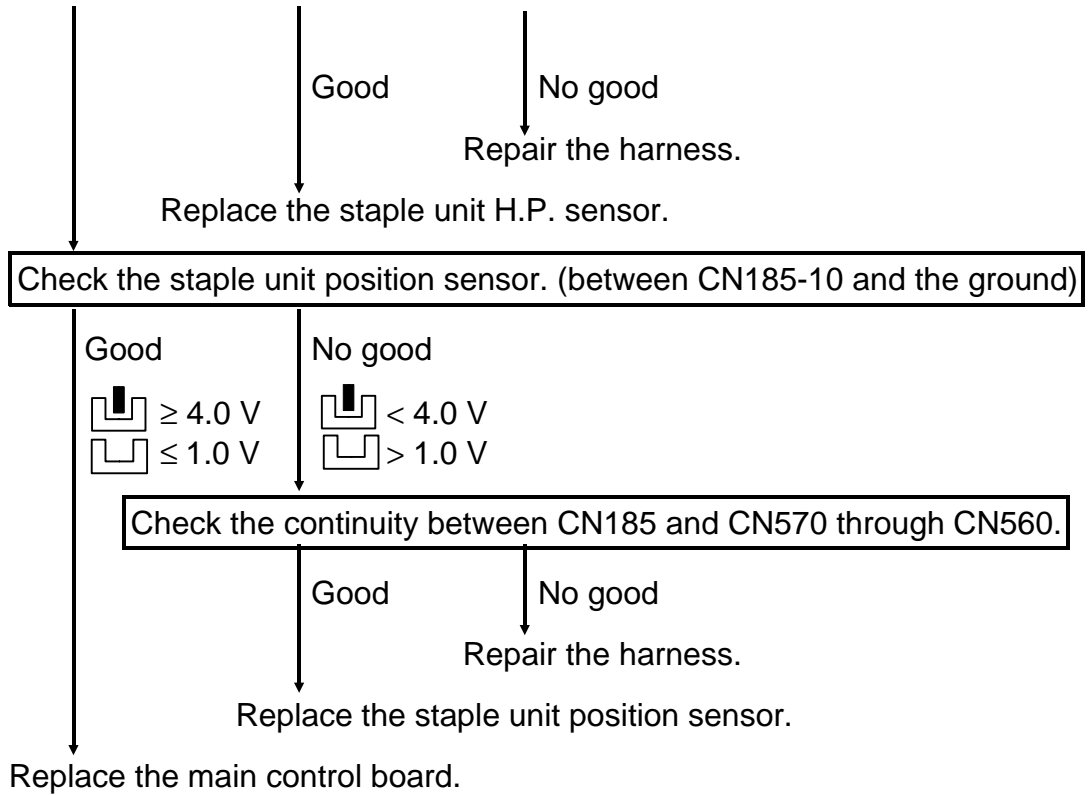

### 17.5 CODE # H5 – GRIP MOTOR ERROR

**- Definition -**

When the grip motor moves forward or backward, the grip H.P. sensor output takes over 250 msec to change.

**- Possible Causes -**

- The grip H.P. sensor is defective
- The grip motor is defective
- The timing belt is not fixed
- The main control board is defective

**- Action -**

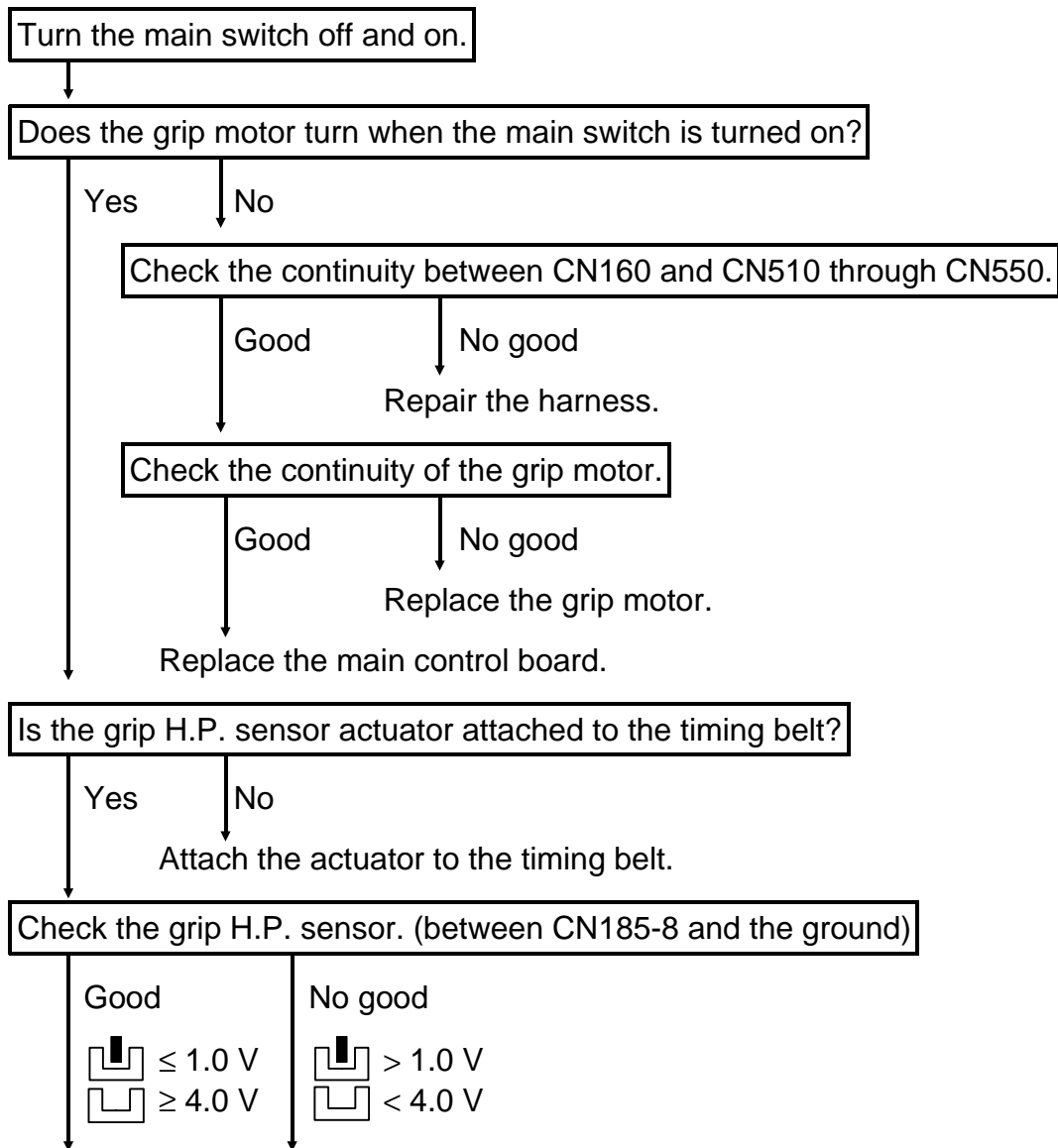

Sorter Stapler

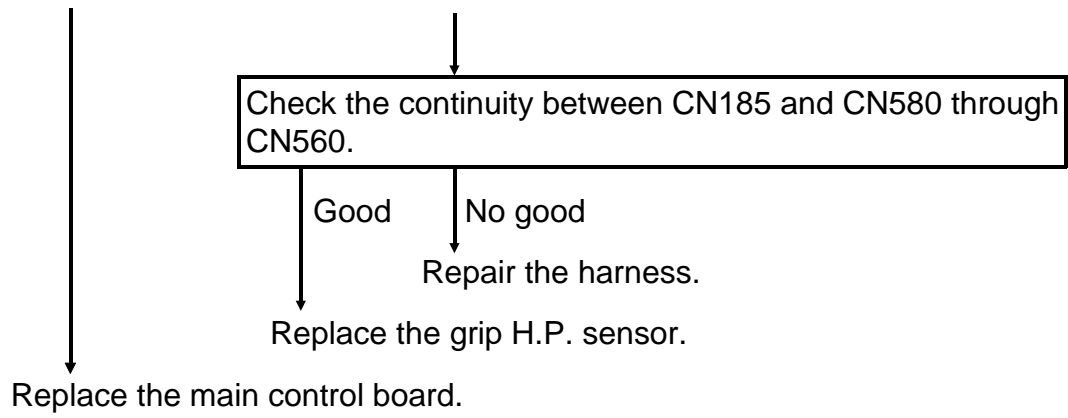

### 17.6 CODE # H6 – STAPLE ERROR

**- Definition -**

The stapler motor takes more than 800 msec for one staple cycle (from H.P. to H.P.).

**- Possible Causes -**

- Stapler is defective

**- Action -**

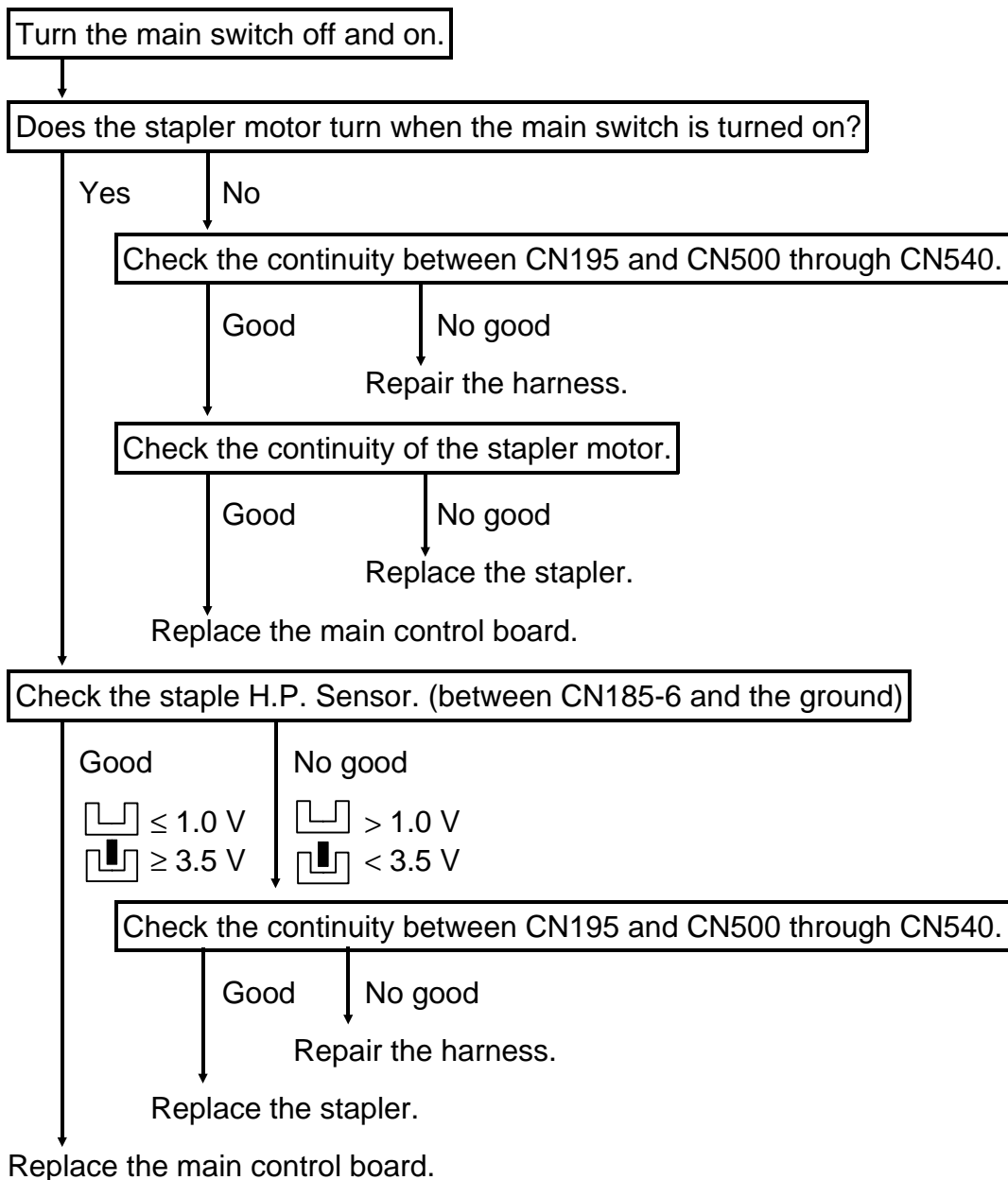

Sorter Stapler

### 17.7 CODE # H7– BIN SIDE PLATE DRIVE MOTOR ERROR

**- Definition -**

- When the bin side plate opens, the bin side plate drive motor takes more than 1 sec to activate the bin side plate release sensor.
- When the bin side plate closes, the bin side plate drive motor takes more than 1.27 sec to activate the bin side plate H.P. sensor.
- The bin side plate H.P. sensor and release sensor turn on at the same time.

**- Possible Causes -**

- The bin side plate H.P. sensor is defective
- The bin side plate release sensor is defective
- The bin side plate drive motor is defective
- The main control board is defective



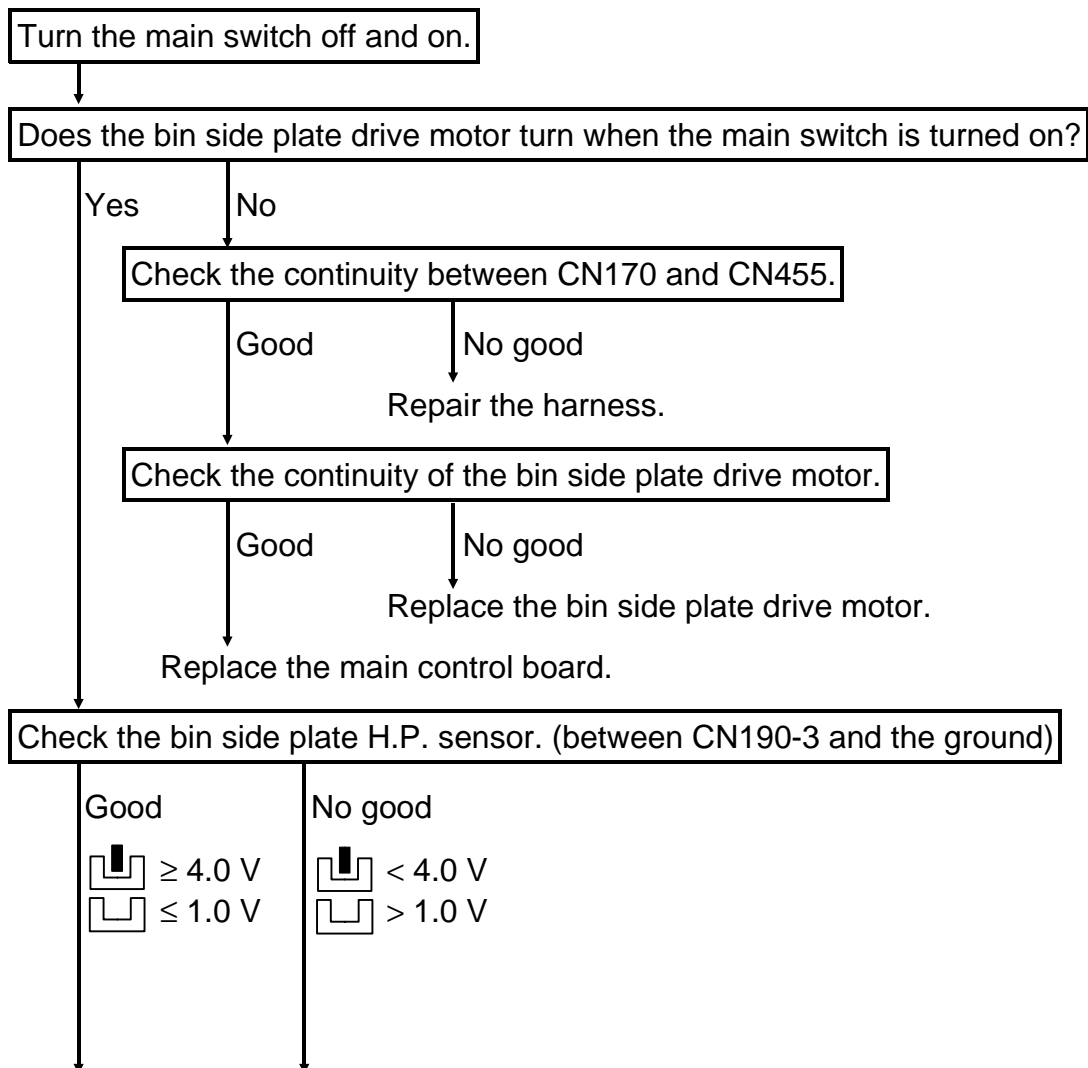

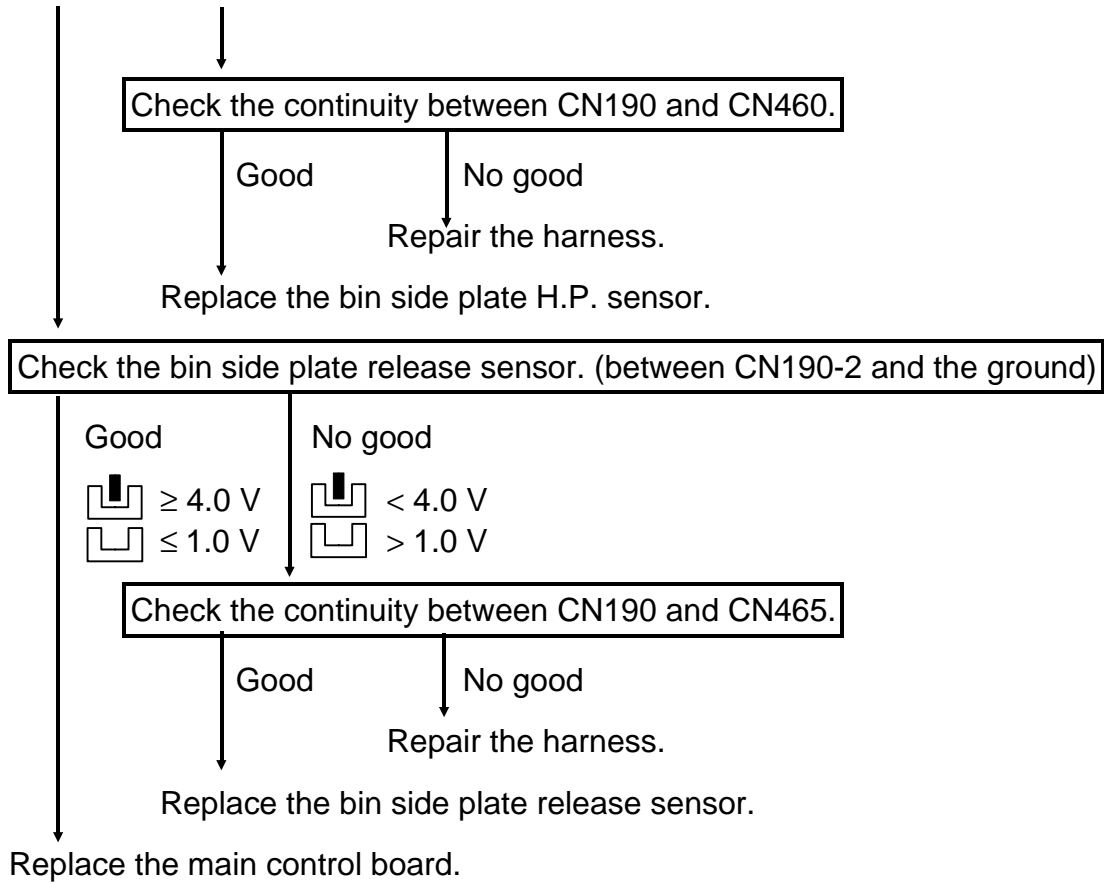

**- Action -**

















## 18. ELECTRICAL COMPONENT DETECTS





### 18.1 SENSORS

Component (Symbol)	CN	Condition	Symptom	
			Main SW turns on	Ready condition
Exit Sensor (S1)  ≥ 4.0 V  ≤ 1.0 V	140-2	open (stays High)	—	"Sorter misfeed" indicator starts blinking, when copies are made in normal mode.
		shorted (stays Low)	"Sorter misfeed" indicator starts blinking.	
Staple Unit H.P. Sensor (S2)  ≥ 4.0 V  ≤ 1.0 V	185-9	open (stays High)	Staple unit goes down and does not return to home position.	After stapling is done, the staple unit does not return to home position.
		shorted (stays Low)	"Sorter misfeed" indicator starts blinking After the front door is opened/closed, the indicator will turn off. However, "SC code (H4)" will be displayed when staple mode is selected.	
Grip H.P. Sensor (S3)  ≤ 1.0 V  ≥ 4.0 V	185-8	open (stays High)	"Sorter misfeed" indicator starts blinking After the front door is opened/closed, the indicator will turn off. However, "SC code (H5)" will be displayed when staple mode is selected.	"Sorter misfeed" indicator starts blinking, or "SC code (H5)" is displayed when copies are made in staple mode.
		shorted (stays Low)	"Sorter misfeed" indicator starts blinking After the front door is opened/closed, the indicator will turn off.	

Component (Symbol)	CN	Condition	Symptom	
			Main SW turns on	Ready condition
Staple Unit Position Sensor (S4)  $\geq 4.0\text{ V}$  $\leq 1.0\text{ V}$	185-10	open (stays High)	—	"Sorter misfeed" indicator starts blinking or "SC code (H4)" is displayed when copies are made in staple mode.
		shorted (stays Low)	"Sorter misfeed" indicator starts blinking. After the front door is opened/closed, the indicator will turn off However, "SC code (H4)" will be displayed when staple mode is selected.	"Sorter misfeed" indicator starts blinking when copies are made in staple mode.
Bin Transport Sensor (S5)  $\geq 4.0\text{ V}$  $\leq 1.0\text{ V}$	180-5	open (stays High)	—	"Sorter misfeed" indicator starts blinking when copies are made in sort/stack or staple mode.
		shorted (stays Low)	"Sorter misfeed" indicator starts blinking	"Sorter misfeed" indicator starts blinking when copies are made in sort/stack or staple mode.
Bin Side Plate Release Sensor (S6)  $\geq 4.0\text{ V}$  $\leq 1.0\text{ V}$	190-2	open (stays High)	—	The bin side plate does not release. The stapler operation is performed without any indication on the display.
		shorted (stays Low)	—	"Sorter misfeed" indicator starts blinking when copies are made in staple mode.



Component (Symbol)		CN	Condition	Symptom	
				Main SW turns on	Ready condition
Bin Side Plate H.P. Sensor (S7)	 $\geq 4.0 \text{ V}$	190-3	open (stays High)	"Sorter misfeed" indicator starts blinking.	"Sorter misfeed" indicator starts blinking when copies are made in staple mode. After the front door is opened/closed, the indicator will turn off. However, "SC code (H7)" will be displayed when staple mode is selected.
	 $\leq 1.0 \text{ V}$		shorted (stays Low)	"Please wait" indicator lights and the bin side plate drive motor turns continuously.	The bin side plate drive motor turns continuously turning when the start key is pressed.
Jogger H.P. Sensor (S8)	 $\geq 4.0 \text{ V}$	190-1	open (stays High)	"Sorter misfeed" indicator starts blinking.	"Sorter misfeed" indicator starts blinking when copies are made in sort/stack or staple mode.
	 $\leq 1.0 \text{ V}$		shorted (stays Low)	"Sorter misfeed" indicator starts blinking. After the front door is opened/closed, the indicator will turn off. However, "SC code (H3)" is displayed when sort/stack or staple mode is selected.	"Sorter misfeed" indicator starts blinking.
Timing Sensor (S9)	 $\geq 4.0 \text{ V}$	180-7	open (stays High)	"Sorter misfeed" indicator starts blinking.	"Sorter misfeed" indicator starts blinking or "SC code (H2)" is displayed when copies are made in sort/stack or staple mode.
	 $\leq 1.0 \text{ V}$		shorted (stays Low)		

Component (Symbol)		CN	Condition	Symptom	
				Main SW turns on	Ready condition
Bin/Jam Sensor - LED (S10)	-	Bin 140-3	open (stays Low)	"Sorter misfeed" location LED starts blinking when sort/stack or staple mode is selected.	"Sorter misfeed" location LED starts blinking when sort/stack or staple mode is selected.
			shorted (stays High)	-	-
		Jam 140-4	open (stays Low)	"Sorter misfeed" indicator starts blinking.	"Sorter misfeed" indicator starts blinking when copies are made in sort/stack or staple mode.
			shorted (stays High)	-	-
Bin/Jam Sensor - Photo Tr. (S11)	 $\geq 4.0 V$	Bin 180-4	open (stays High)	-	No staple operation even though copying is completed in staple mode.
			shorted (stays Low)	-	"Remove copies from the copy tray" is displayed when sort/stack or staple mode is selected.
	 $\leq 1.0 V$	Jam 180-6	open (stays High)	-	"Sorter misfeed" indicator starts blinking when copies are made in sort/stack or staple mode.
			shorted (stays Low)	"Sorter misfeed is displayed."	"Sorter misfeed" indicator starts blinking when copies are made in sort/stack or staple mode.
Paper Sensor (S12)	 $\leq 1.0 V$	180-5	open (stays High)	-	"Sorter misfeed" indicator starts blinking and no staple operation when copies are made in staple mode.
	 $\geq 4.0 V$		shorted (stays Low)		No staple operation even though a set of copies is at the staple position.

**Sorter Stapler**

Component (Symbol)	CN	Condition	Symptom	
			Main SW turns on	Ready condition
Staple H.P. Sensor (S13)	185-6	open (stays High)	"Sorter misfeed" indicator starts blinking. After the front door is opened/closed, the indicator will turn off. However, "SC code (H6)" will be displayed when staple mode is selected.	"Sorter misfeed" indicator starts blinking or "SC code (H6)" is displayed when copies are made in staple mode.
		shorted (stays Low)	—	
Staple End Sensor (S14)	185-7	open (stays High)	—	"Add staple" indicator lights even though the staple cartridge is not empty when staple mode is selected.
		shorted (stays Low)	—	"Add staple" indicator does not light even though the staple cartridge is empty when staple mode is selected.

**18.2 SWITCHES**

	Component and Condition		Symptom
	Door Safety SW (AC) (SW1)	Door Safety SW (DC) (SW2)	
Main SW OFF→ON	open	open	"C-5" is displayed even though sorter front door is closed.
	open	shorted	"Sorter misfeed" indicator starts blinking although there is no paper in sorter stapler.
	shorted	open	"C-5" is displayed even though sorter front door is closed.
	shorted	shorted	"C-5" is not displayed even though sorter front door is opened.
Ready Condition	open	open	"C-5" is displayed even though sorter front door is closed.
	open	shorted	"Sorter misfeed" indicator starts blinking or "SC code (H2)" is displayed when copies are made in sort/stack or staple mode.
	shorted	open	"C-5" is displayed even though sorter front door is closed.
	shorted	shorted	"C-5" is not displayed even though sorter front door is opened.

## 19. OTHERS

### 19.1 IMPROPER STAPLING

#### - Phenomenon -

- Incomplete stapling: The staples are not flush with the paper surface.

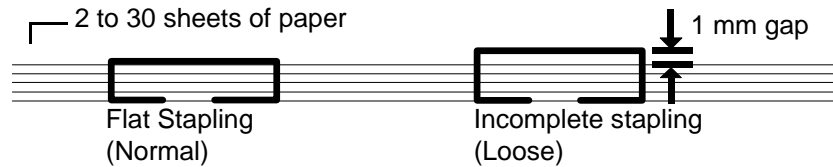

- No stapling: No staples are dispensed from the stapler.

#### - Possible Causes -

1. If a staple [A] jams inside the staple bending gate [B], the gate cannot close completely. Staples are not crimped completely, and there is about a 1 mm gap between the staple and the paper surface.

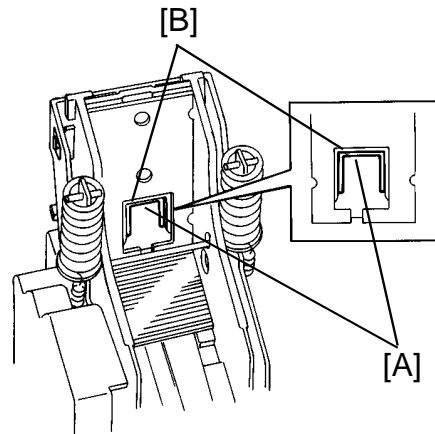

2. A bent staple prevents the staple push plate [C] from moving downward. Another possibility is that the staple sheet has not yet reached the stapling position.

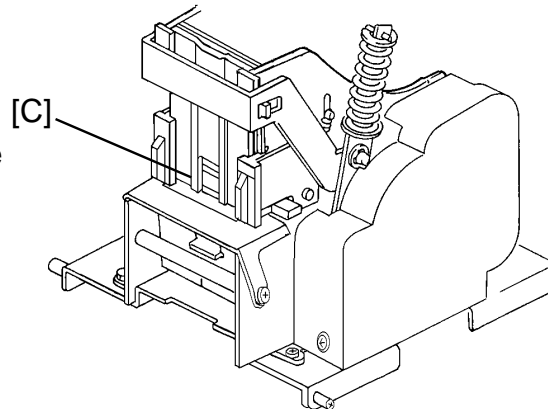

#### - Action -

1. Remove the jammed staple [D] from the staple bending gate [E].

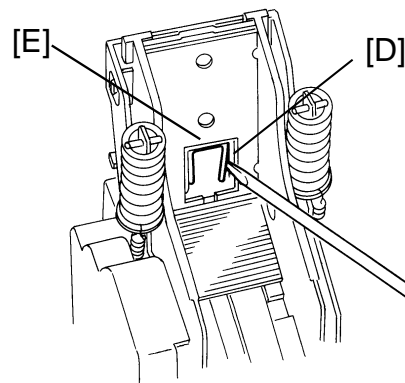

2. (1) Remove the staple cartridge, then check for any staples jammed in the stapling mechanism [A]. To remove jammed staples, spread apart the side plates [B] and slide up the front pressure guide plate [C].

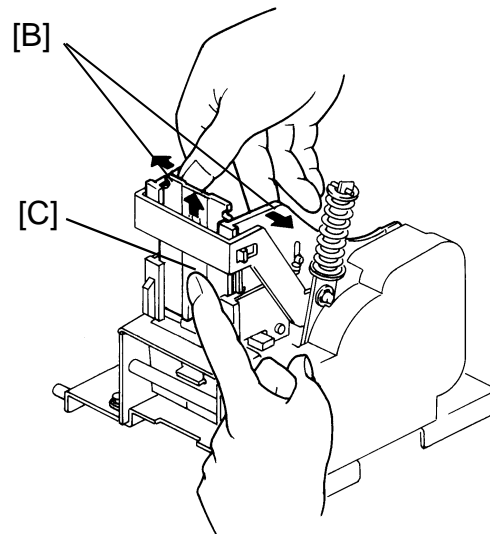
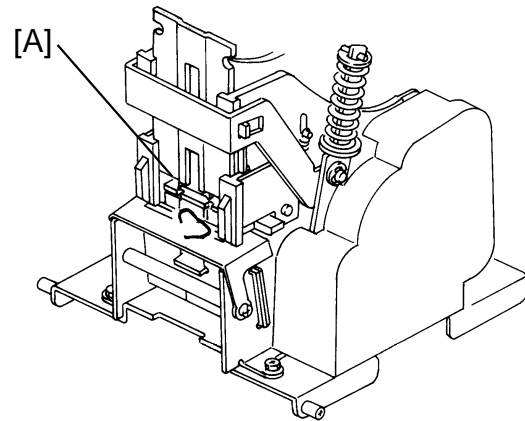

**NOTE:** When installing the staple cartridge, make sure that all the staple sheets [D] are in the initial position.

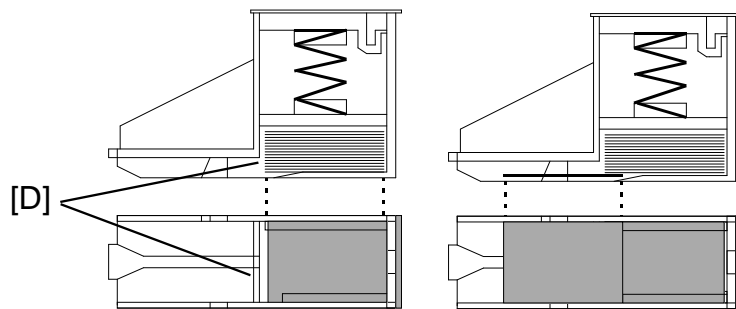

- (2) Install the staple cartridge, then make copies in staple mode until the staple sheet reaches the stapling position.

Correct

Incorrect

Sorter Stapler